

CertainTeed
MEMBRAIN™
The SMART Vapor Retarder

Air Barrier Installation Instructions for Wood Framing



In addition to performing as an interior vapor retarder, MemBrain™ the Smart Vapor Retarder may be installed as a continuous, interior air barrier system over unfaced fiber glass or other insulation requiring a separate vapor/air barrier. MemBrain™ is recommended for interior vapor retarder and air barrier applications, located at the “warm in winter” (moderate to high heating climates) side of the building envelope. MemBrain™ sheeting is not intended for exterior applications where it would be exposed to the elements or UV light.

General Instructions

MemBrain™ sheeting may be installed as an interior air barrier system. Install large sheets using recommended fasteners, tapes and sealants to achieve air barrier continuity with the building envelope components, as illustrated in Figure 1.

The most effective time to install the MemBrain™ Air Barrier System is:

- After all building envelope penetrations are complete (i.e. plumbing lines, electrical outlets, exhaust vents, lighting fixtures, etc...) and vertical penetrations through wall plates in cavities are appropriately sealed.
- After all windows and doors are installed, and rough opening gaps are sealed appropriately (i.e. with code approved low expansion foam).
- After wall systems are insulated with unfaced fiber glass insulation.
- Before exterior walls and ceilings are finished with gypsum board.

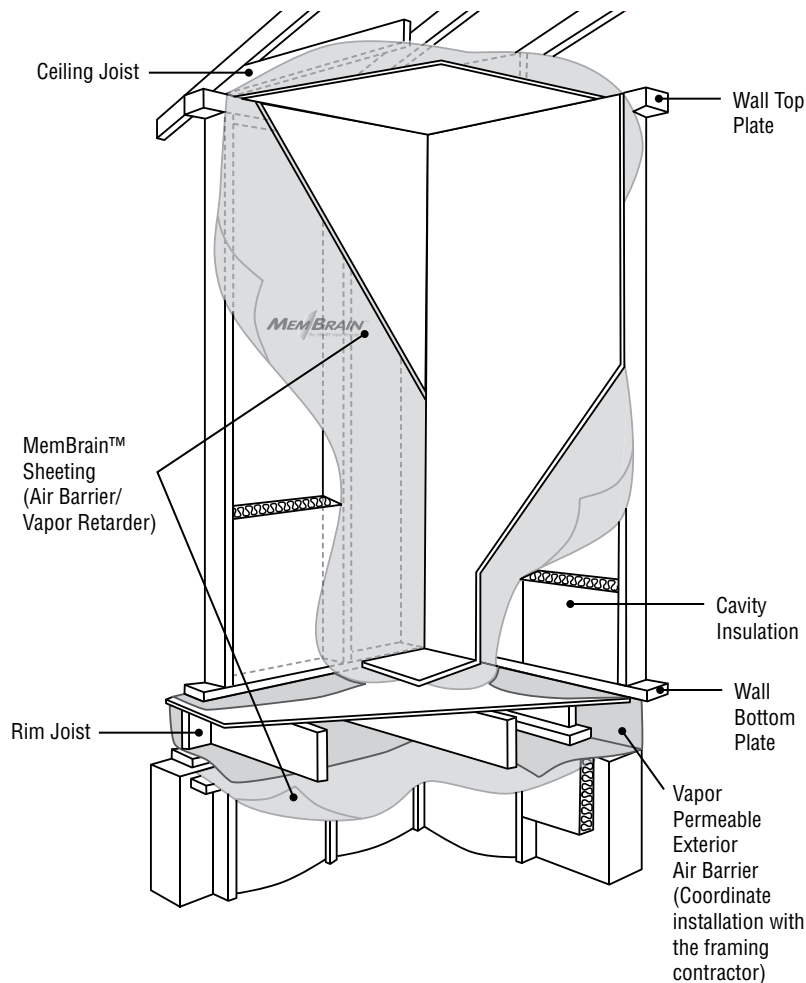

Figure 1: Maintain air barrier continuity at rim joists, corners, partition wall interfaces and ceilings.

Required Materials

The following materials should be used to create the MemBrain™ Air Barrier System:

- MemBrain™ sheeting available in 8' 3", 9' 3", 10' 3" and 12' 3" widths, 100' lengths (2,515 mm, 2,819 mm, 3,124 mm and 3,734 mm widths, 30.48 m length)
- Recommended Sealants: Acoustical or silicone-based sealants conforming to ASTM C 920 or C 834 specifications.
- Recommended Tape: Canadian Construction Materials Centre (CCMC) evaluated or other code approved sheathing tapes.

Roof/Attic/Ceiling Applications

1. Staple MemBrain™ to the bottom of ceiling joists every 12 to 24 inches.
2. Seal the film to interior and exterior wall top plates using recommended sealants.
3. Fasten the film using staples through the sealant to the plates every 12 to 24 inches.
4. Allow the film to overlap at the corners a minimum of 6 inches.

Exterior Wall Applications

1. Start at a corner of the room where an interior partition wall or door jamb meets an insulated exterior wall. Lay the MemBrain™ roll on the floor, with the end touching the bottom of the partition wall or jamb.
2. Unroll the MemBrain™ along the insulated wall, until the next corner is reached. Cut the film perpendicular to the insulated wall so that the overall length is about 8 to 12 inches longer than the wall.
3. With the 3-inch offset edge parallel with the top of the insulated wall, place one corner of the cut sheet at the top left or right corner of the wall. The factory cut edge should be covering the top edge of the top sill plate. The cut edge of the sheet should wrap around the inside corner at least 4 inches. Ensure that the folded material is facing the room (the print across top header will be facing out).
4. Apply recommended sealant over ceiling overlapped film material at the top plate, to the frame around window and door rough openings and to the bottom plate (See MemBrain™ Air Barrier System Details, and Figure 17, page 10). Working towards the opposite corner, pull the sheet tight, and staple the offset edge to the top sill plate through the sealant bead. Staples should be at least 12 to 24 inches apart.
5. After stapling to the opposite corner, allow the folded sheet to unfold to the floor. (See Figure 2)
6. Pull the sheet downward and staple through the sealant bead to the bottom sill plate. Then staple at 12- to 24- inch intervals along each stud. Effort should be made to minimize wrinkles along the stud surfaces to make drywall installation easier.
7. Follow the MemBrain™ Air Barrier System Details below to ensure an air-tight assembly.

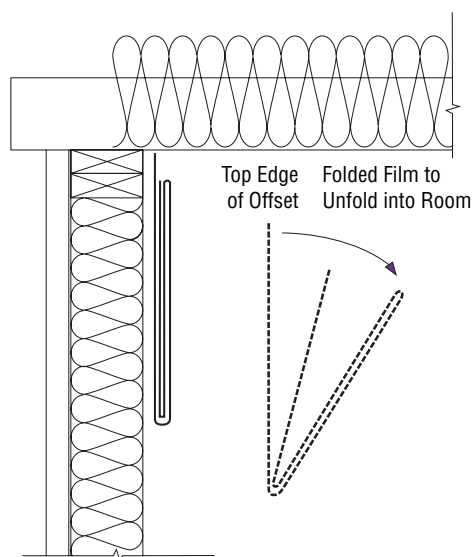

Figure 2: MemBrain™ sheeting orientation for wall installation method.

MemBrain™ Air Barrier System Details

Acoustical and Silicone-based Sealant Application at Sheet Terminations – Figures 3 and 4

- Use a combination of staples and recommended sealants to attach MemBrain™ to the top plate, bottom plate and end studs.
- Place a 1/4 inch to 3/8 inch bead of sealant over the stud surface.
- Place the film over the sealant without tension and lightly press to ensure complete contact.
- Secure the MemBrain™ sheet through the adhesive bead with 1/2 inch staples every 12 to 24 inches.

Lapped Joint Treatment – Figure 5

- Apply a recommended sealant to the wood stud surface.
- Overlap the MemBrain™ sheet a minimum of 6 inches.
- Staple through the sealant to the studs every 6 to 12 inches.
- Seal the overlapped joint using recommended sheathing tape.
- All vertical and horizontal seams should be treated as described above.

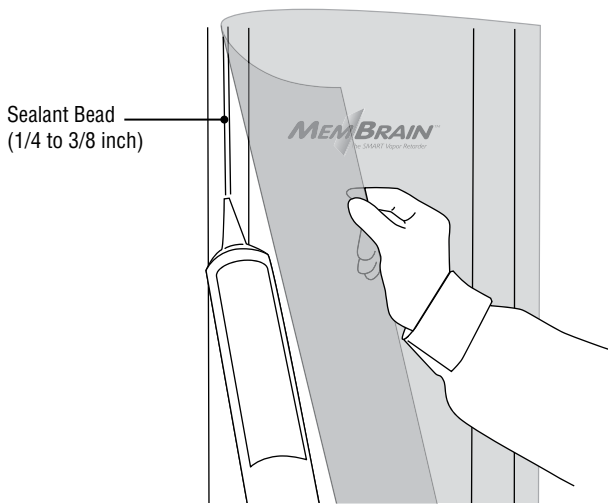

Figure 3: Sealant application.

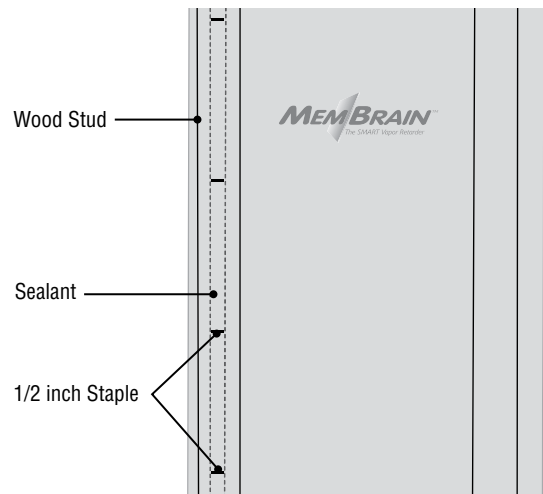

Figure 4: Fastener application.

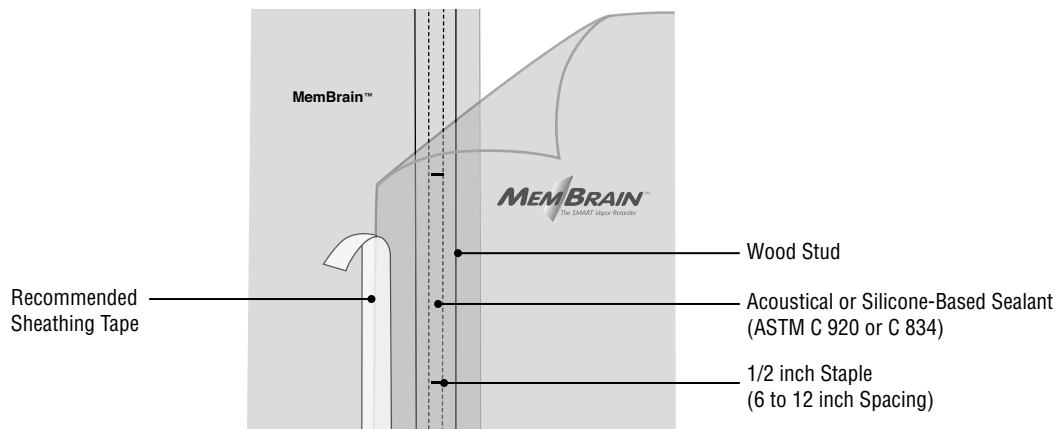

Figure 5: Overlapping seam treatment.

Penetrations – Figure 6 through 11

- Building envelope penetrations include windows, doors, dryer vents, bathroom exhaust fans, electrical outlets, gas lines, plumbing, etc. (See Figure 6)
- Cut and fit the MemBrain™ sheeting tightly around the penetrations. (See Figure 7)
- Seal the film around all electrical, HVAC and plumbing penetrations with recommended sealants or sheathing tapes.

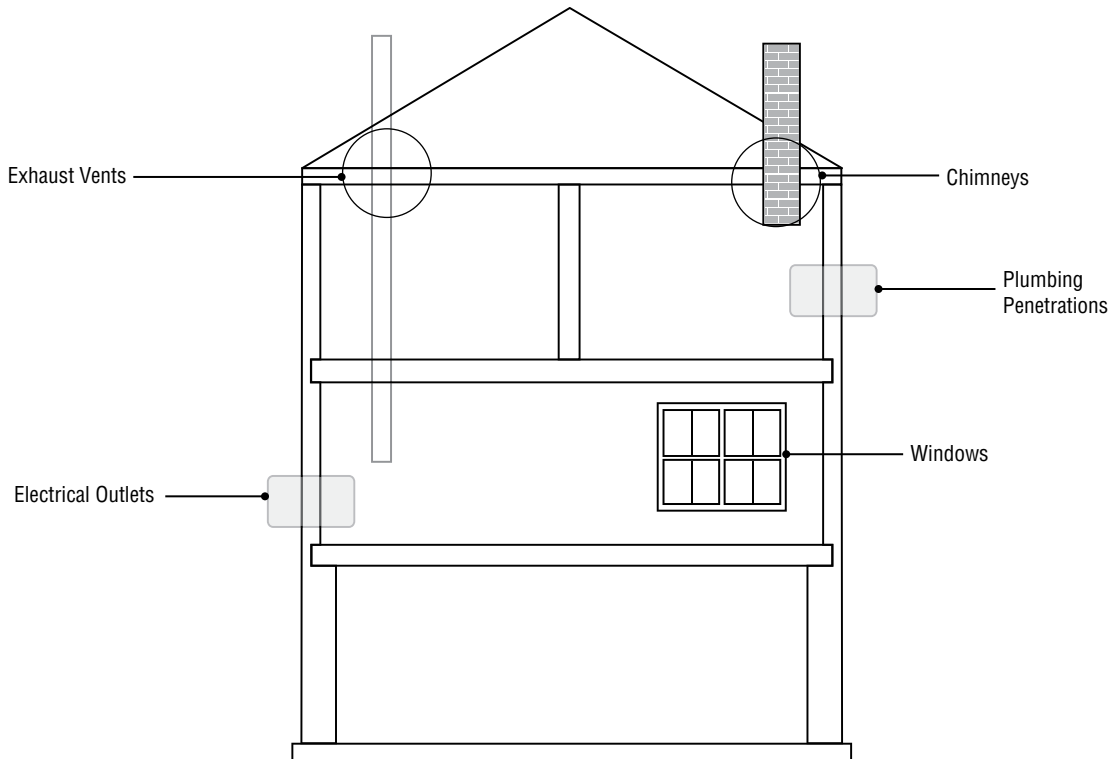

Figure 6: Building envelope penetrations.

Window and Door Treatment – Figures 7 through 10

- Cut the MemBrain™ sheet to fit the rough opening.
- Slit the film at the corners. (See Figure 7)
- Apply recommended sealant between the film and the window frame.
- Staple through the sealant to the window head, jambs and sill. Seal the window to the rough opening with recommended sealant. (See Figure 8)
- Apply recommended sealant between interior finishing material (typically gypsum board) and the attached MemBrain™ sheet. (See Figure 9)

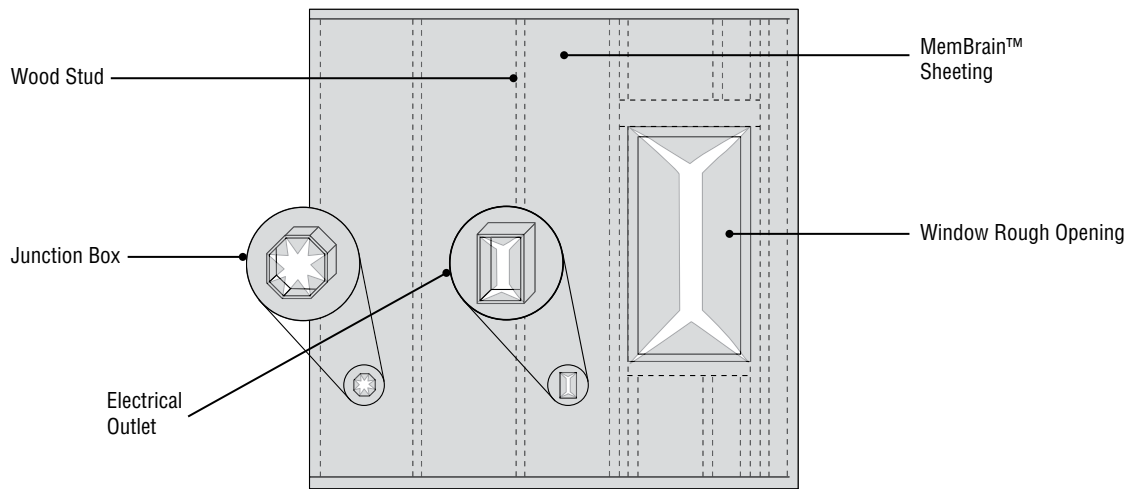

Figure 7: Cut MemBrain™ sheeting to tightly fit penetrations.

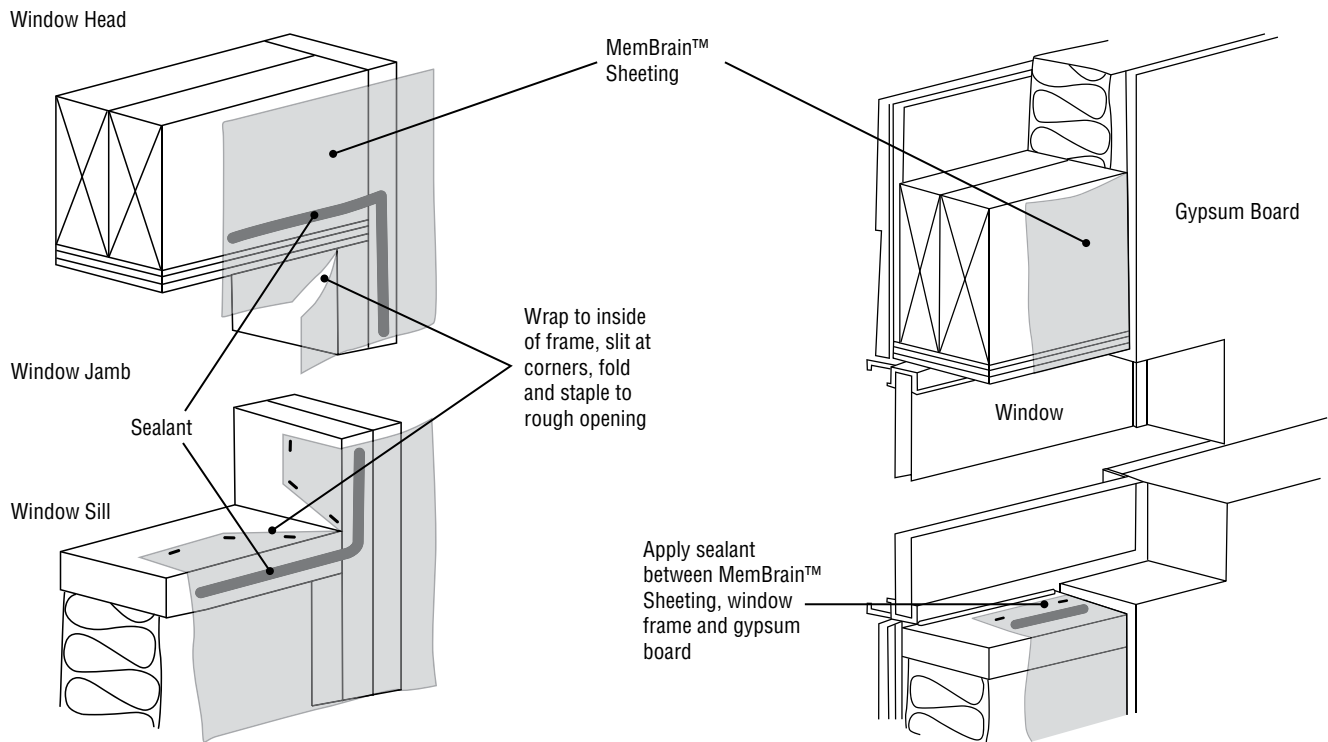

Figure 8: Window rough-opening treatment.

Figure 9: Window finish treatment.

Large Circular Penetrations – Figures 10 and 11

- Trace the penetrations circumference on a separate piece of MemBrain™ sheeting.
- Cut a square piece of film with a minimum 6 inch clearance from the penetration outline.
- Intersect the circle with four diameter lines. (See Figure 10)
- Cut according to these lines towards the circle's perimeter.
- Place the square patch over the penetration. (See Figure 11)
- Seal the cut edges to the penetration with recommended sheathing tape.
- Seal the square patch to the continuous sheet surface without film tension using recommended sheathing tape and lightly press to ensure complete contact.

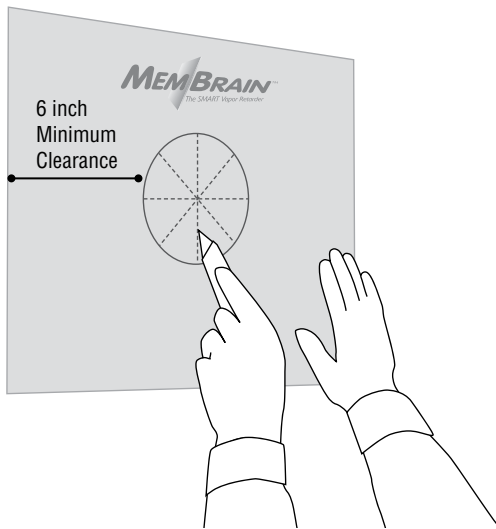

Figure 10: Patch preparation.

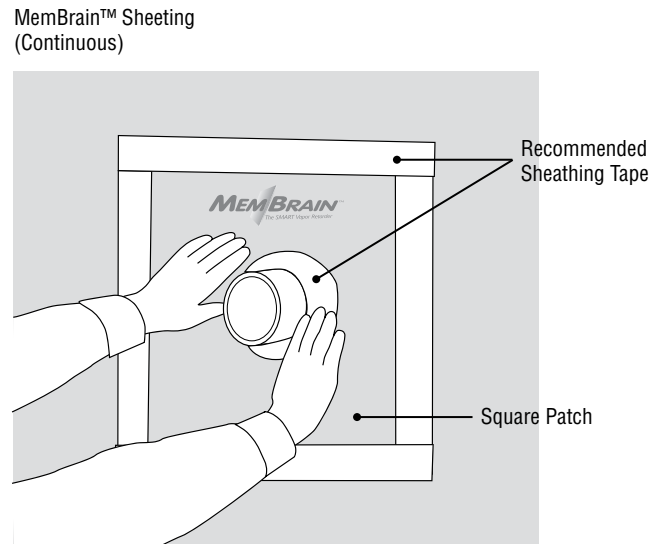

Figure 11: Patch attachment.

MemBrain™ Sheet Tears and Holes

- Cover all tears and holes with recommended sheathing tape.
- Treat large holes (greater than 1 inch) like large penetrations using a square patch.

Electrical Outlets – Figures 12 and 13

- Wrap and seal electrical boxes using recommended sheathing tapes and sealants.
- Airtight plastic boxes are recommended.

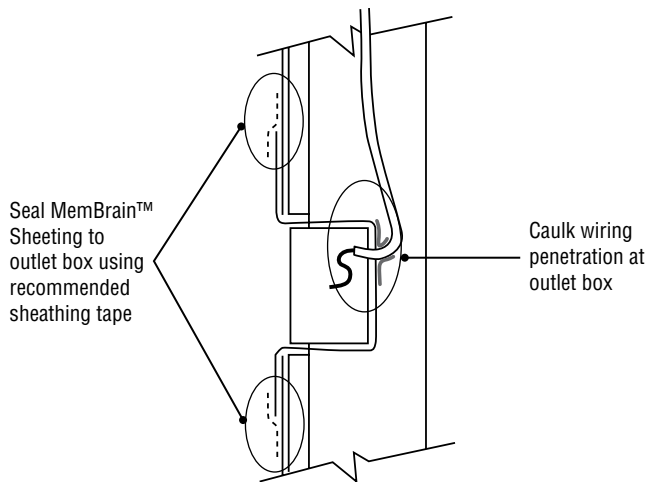

Figure 12: Sealed interior electrical outlet.

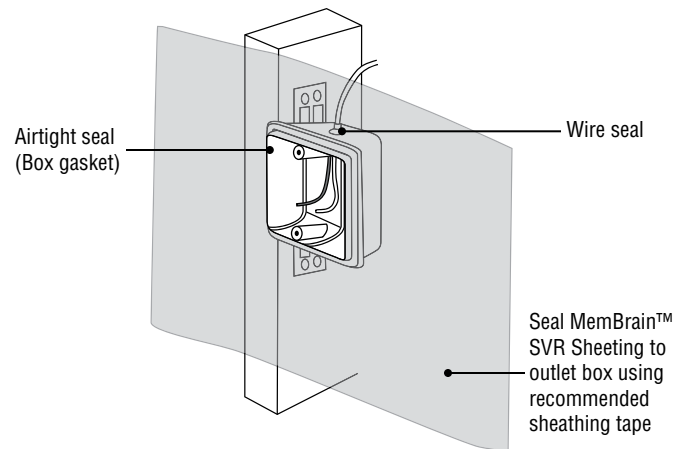

Figure 13: Airtight electrical outlet box.

Plumbing Penetrations – Figure 14

- Secure plumbing lines to a rigid mounting panel.
- Seal penetrations using recommended sealants.
- Attach MemBrain™ sheeting to mounting panel using recommended sealants.

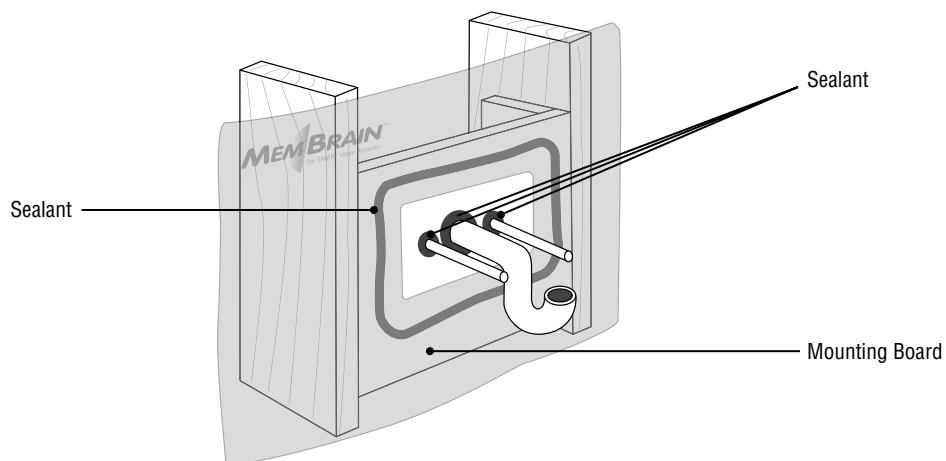

Figure 14: Mounted and sealed plumbing penetrations.

Air Barrier System Continuity – Figures 15 - 18

- Maintain air barrier system continuity at wall, ceiling, floor and foundation intersections. Use recommended sealants. Seal between framing and film overlaps.
- Coordinate installation details with framing and insulation trade contractors.
- Insulate rim and band joists with fiber glass insulation batts wrapped or pillowed with MemBrain™ sheeting.

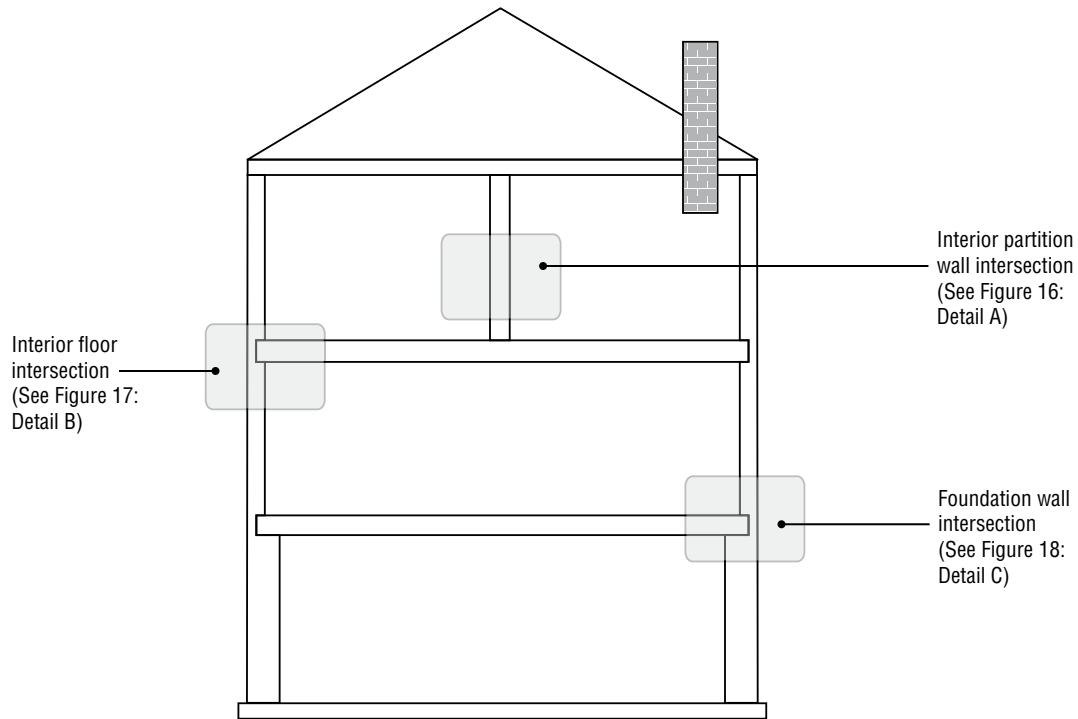

Figure 15: Building envelope intersection locations.

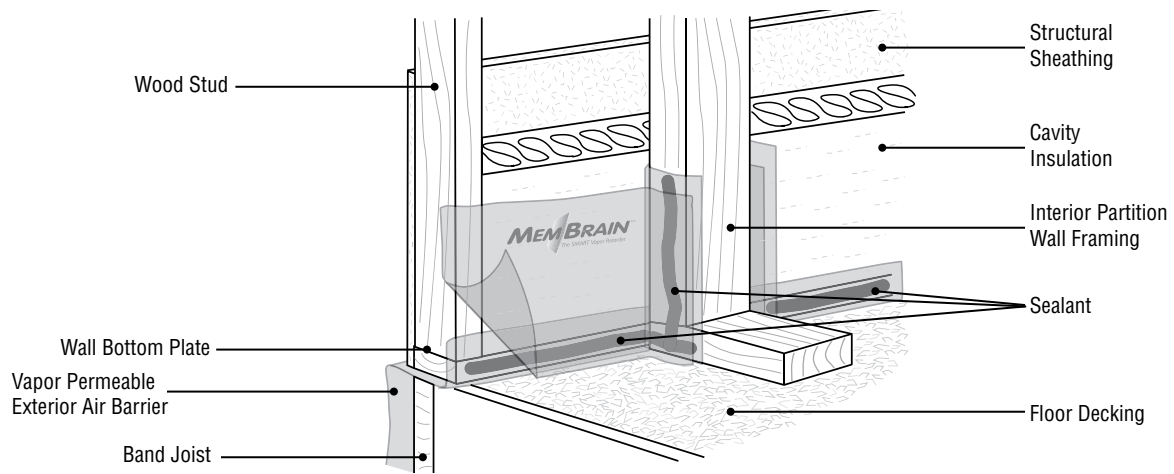

Figure 16: Detail A – MemBrain™ Air Barrier System interior partition intersection details.

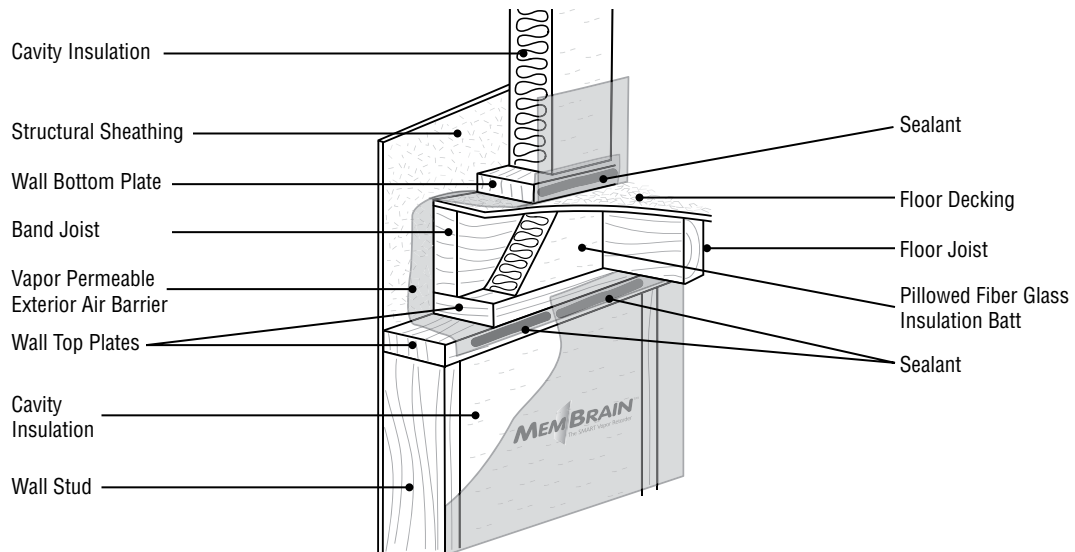

Figure 17: Detail B – MemBrain™ Air Barrier System interior floor intersection details.

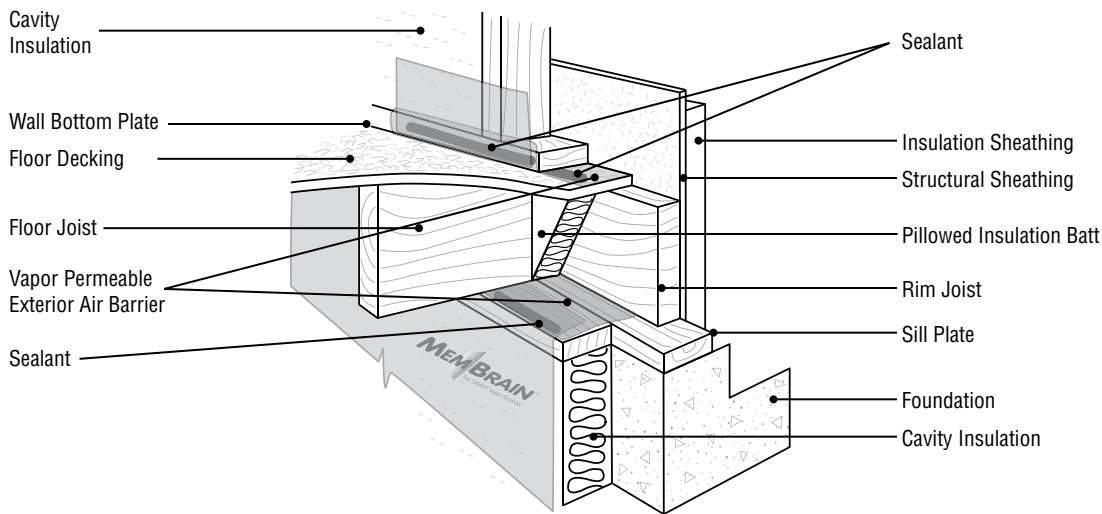

Figure 18: Detail C – MemBrain™ Air Barrier System Foundation wall intersection details.

Recommended References

- CCMC Evaluation Report 13278-R
- Super Good Cents Builder's Field Guide to Energy Efficient Construction – Chapter 9, “Air Tightening Specialists,” Bonneville Power Administration, Publication #DOE/BP-2651, 1992.
- Best Practice Guide, Building Technology – Wood-frame Envelopes, “Details: Wall Assembly A – Basic Stud Wall with Polyethylene Air Barrier and Vapour Retarder,” Canadian Mortgage and Housing Corporation (CMHC), pg 7-3 to 7-9, 2006.
- Air Barrier Association of America, <http://www.airbarrier.org>



ASK ABOUT OUR OTHER CERTAINTEED PRODUCTS AND SYSTEMS:

EXTERIOR: ROOFING • SIDING • WINDOWS • FENCE • RAILING • TRIM • DECKING • FOUNDATIONS • PIPE
INTERIOR: INSULATION • GYPSUM • CEILINGS

CertainTeed Corporation
P.O. Box 860
Valley Forge, PA 19482

Professional: 800-233-8990
Consumer: 800-782-8777
www.certainteed.com

CertainTeed 