

CertainTeed

# Gypsum Board Systems Manual

Fire Resistance and Sound Control Design Manual

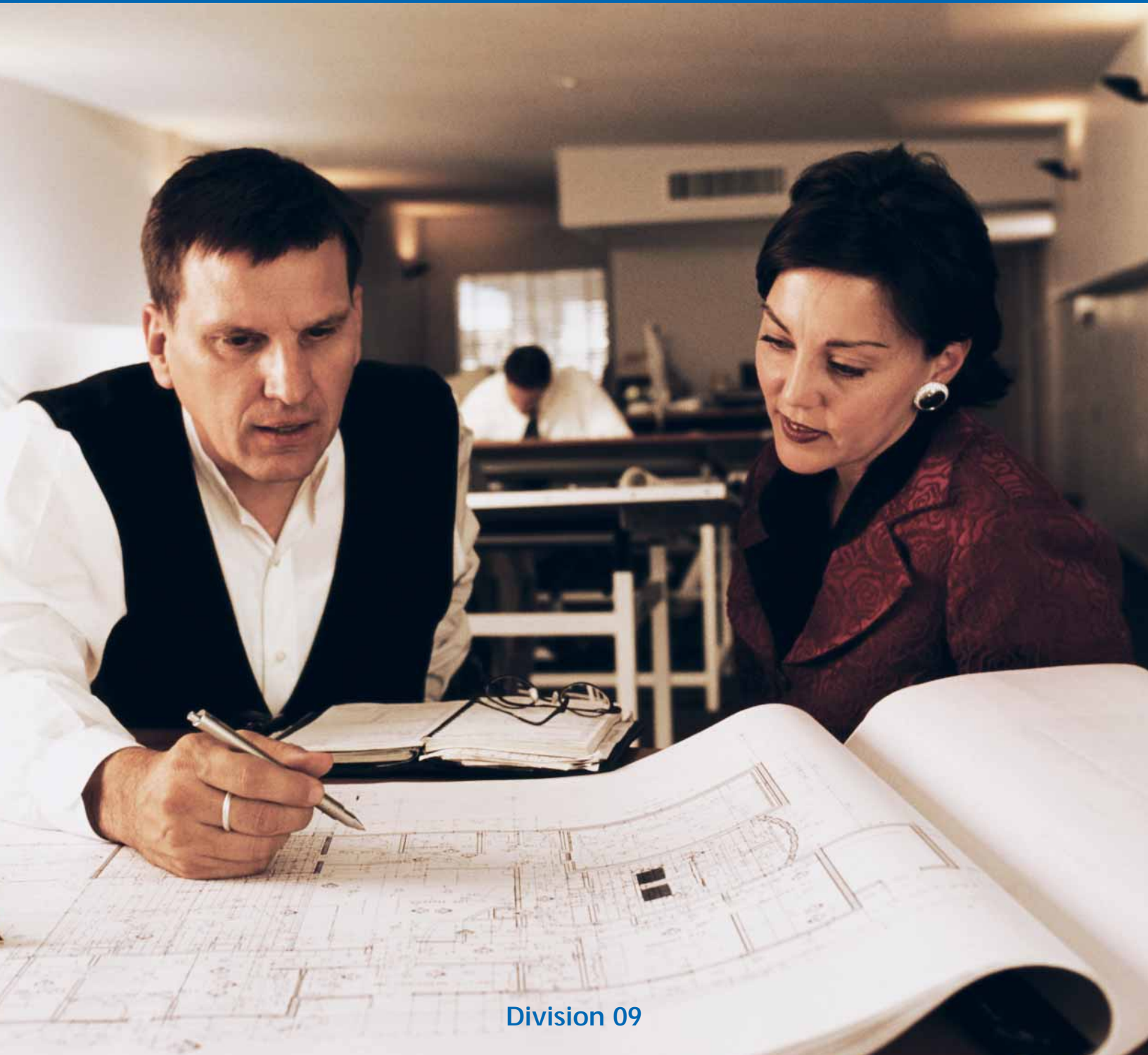

Division 09

### GENERAL

This manual is intended to provide architects, engineers and builders with reference data on Gypsum Board Systems incorporating CertainTeed Corporation gypsum board products. It contains sections on Partitions, Exterior Walls, Floors and Ceilings, Shaftwalls, Cement Board and Column and Beam Protection. Each section lists the systems in ascending order of fire rating, and includes sound ratings and basic construction details.

The Gypsum Board Systems Manual is available on CD-ROM and on our web site at [www.certainteed.com](http://www.certainteed.com). Further assistance regarding the application of CertainTeed Corporation products in Gypsum Board Systems can be obtained by calling the CertainTeed Corporation office nearest you.

“Any product information, data or specifications contained in this Manual have been prepared with information available to CertainTeed Corporation at the time of printing and every effort has been made to ensure that all information, data and specifications are complete and accurate. Anyone making use of, or relying on, any information, data or specifications contained in this Manual, for any purpose whatsoever, expressly assumes any and all liability that may arise from such use or reliance. CertainTeed Corporation does not assume any responsibility for any errors or omissions that may be contained in this Manual. Any information, data or specifications contained in this Manual supercede any and all previous information, data or specifications prior to this manual and are subject to change without notice.”

## FIRE RESISTANCE

After two hour exposure to heat following CAN/ULC-S101 time-temperature curve:

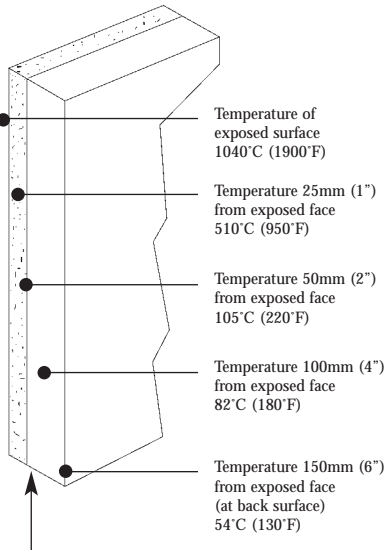

Vertical line represents plane of calcination. Temperature never greatly exceeds 100°C (212°F) behind plane of calcination.

### How Gypsum Retards Heat Transmission

Gypsum board is the most commonly used fire resistive material and is equally well known as a reliable and economic surfacing material. When used in combination with other products, excellent fire resistive and sound control properties can be achieved.

Gypsum is a naturally occurring mineral mined or quarried in many locations throughout North America and in other parts of the world. When processed into gypsum board products the chemically combined water (about 21 percent by weight) contributes to its effectiveness as a fire barrier. When gypsum protected structural members are exposed to fire, the water is slowly released as steam, effectively retarding heat transmission and acting as a fire barrier until most of the chemically combined water is eliminated, a process known as calcination. The temperature directly behind the plane of calcination is only slightly higher than that of boiling water (100°C), and that is considerably below the temperature at which steel begins to lose its strength or lumber ignites. Once the gypsum is completely calcined, the residue acts as an insulating barrier to the flames.

DSG, or desulphogypsum, is high purity gypsum that is produced instead of mined. Traditionally, the gypsum raw material in the core of drywall has been mined from natural deposits. There are numerous underground and surface mines producing this gypsum for drywall manufacturing plants across North America. DSG is fundamentally the same raw material as mined gypsum, with a higher degree of purity. As a result, its properties are virtually the same as mined gypsum.

### Type X Gypsum Board

There are two basic classifications of gypsum board core formulations giving different degrees of fire resistance. These are Standard and Type X gypsum board. Type X board by definition is a gypsum board that provides: a 60 minute fire endurance rating for a 15.9mm (5/8") thickness when applied in a single layer and properly fastened to each side of 92mm (3 5/8") steel framing members

or

a 2 hour fire retardant rating for a 12.7mm (1/2") thickness when applied in a double layer and properly fastened to each side of 64mm (2 1/2") steel framing members, when tested in accordance with CAN/ULC-S101.

Type X gypsum boards manufactured by CertainTeed Gypsum are described as ProRoc Type X and these products are certified by Underwriters' Laboratories and Underwriters' Laboratories of Canada.

All CertainTeed Gypsum ProRoc Type X, ProRoc Type C, ProRoc Moisture Resistant Type X, ProRoc Moisture Resistant Type C, ProRoc Treated Core Sheathing Type X and ProRoc Treated Core Sheathing Type C products meet both the CSA and ASTM definitions of Type X gypsum board.

ProRoc Type C and ProRoc Moisture Resistant Type C and ProRoc Treated Core Sheathing Type C are proprietary products which meet the requirements of Type X and have further enhanced fire resistive properties. These products are often referred to as "Type C" gypsum board, although there is no industry definition for "Type C" gypsum board.

### Fire Resistance Tests

There are a number of independent testing authorities capable of conducting fire tests to establish fire resistance classifications according to procedures outlined in:

CAN/ULC-S101 "Fire Endurance Tests of Building Construction and Materials."

ASTM E 119 "Fire Tests of Building Construction and Materials."

The conditions for tests are thoroughly detailed and the time of failure is the time at which there is excessive heat transmission, passage of flame or structural failure. In addition, failure may result because of penetration by a pressurized hose stream required in the fire test procedure for walls.

Comprehensive research by fire protection agencies has determined the average combustible content to be expected for a given occupancy; also the time required for the contents to be consumed by fire and the resulting temperature. Thus, the average fire load may be predicted for a given occupancy, and fire resistance classifications are assigned accordingly in building codes and similar regulations.

In CAN/ULC Standard S101 fire tests, various wall, floor, roof, column and beam assemblies are exposed in a furnace which reaches the indicated average temperatures at the time stated in the standard time-temperature curve.

All of the walls and partitions tested and classified must be at least 9.3m<sup>2</sup> (100ft<sup>2</sup>) with no side dimension less than 2.75m (9 feet). Temperatures are measured at a minimum of nine points on the unexposed surface of the assembly. When testing load bearing walls and partitions the superimposed load applied shall simulate the working stress of the construction components.

The wall or partition must also stop flame or hot gasses capable of igniting cotton waste. The average temperature of the unexposed surface cannot increase more than 139°C (250°F) above ambient nor shall the temperature rise at any individual point exceed 181°C (325°F). It is also required that a duplicate of the assembly be fire tested for half the specified resistance period, after which it must withstand the impact, erosion and cooling effect of water under high pressure from a fire hose.

Floor and roof assemblies tested and classified have to be a minimum of 16.8m<sup>2</sup> (180ft<sup>2</sup>) with neither dimension less than 3.66m (12 feet). The assemblies must sustain the design load throughout the test and not allow either flame or hot gasses, capable of igniting cotton waste, to pass through. The unexposed surface temperature may not rise more than an average of 139°C (250°F) above the initial temperature nor shall the temperature rise at any individual point exceed 181°C (325°F).

### Surface Burning Characteristics

Flame spread ratings are intended as a guide in the selection and use of finishing materials and are obtained by measuring the extent and rapidity with which flames spread over their surfaces under test conditions.

Under certain circumstances some building codes may require the use of interior finish materials with a flame spread rating of not more than 25. The laboratory test generally used to establish a material's flame spread characteristic is referred to as the tunnel test:

CAN/ULC-S102 "Test for Surface Burning Characteristics of Building Materials and Assemblies."

This test measures relative flame spread, fuel contribution and the amount of smoke developed from the material being tested.

A method of numerical classification to permit comparison of a given material's flame spread performance with that of another has been established.

### Flame Spread Rating

Asbestos cement board 0 (control classification)

**Gypsum plaster**            **0**

**Gypsum lath**                **10**

**Gypsum board**            **10-15**

**Gypsum sheathing**       **15-20**

Red oak                        100 (control classification)

The fuel contributed by gypsum board is rated at 15 while the smoke developed is 0.

## SOUND CONTROL

### Sound Transmission Class (STC)

Drywall construction systems are tested to establish their sound insulation characteristics and airborne sound insulation is reported as the Sound Transmission Class (STC).

ASTM Standard E 90 "Laboratory Measurement of Airborne Sound Transmission Loss of Building Partitions" outlines a procedure for measuring sound transmission loss which is the difference between the sound energy in a source room and a receiving room when the two rooms are separated by the assembly being tested. The sound transmission loss is measured at different test frequencies and this data is used to obtain a single number known as the STC rating calculated in accordance with ASTM E 413.

### Sound Insulation

STC values stated are based on laboratory tests. The actual STC ratings of assemblies as constructed may be significantly less due to deviations from the design or specified materials, flanking paths or poor workmanship. A first essential for airborne sound insulation using any assembly is to close off air leaks and flanking paths by which noise can go around the assembly. Hairline cracks or small holes will increase the sound transmission at the higher frequencies. This can have a detrimental effect on the overall acoustical performance and the STC particularly for higher rated assemblies.

Assemblies should be airtight. Recessed wall fixtures such as medicine cabinets, or electrical, telephone and television outlets, which perforate the gypsum board surface, should not be located back-to-back or in the same cavity. In addition, any opening for such fixtures and for piping outlets should be carefully cut to proper size and caulked. The entire perimeter of a sound insulating assembly must be made airtight to prevent sound flanking. An acoustical caulking compound or acoustical gasket should be used to seal between the assembly and all dissimilar surfaces. Taping gypsum board wall and wall-ceiling intersections provides an adequate air seal at these locations. Details of some typical problem areas and their recommended treatments are shown in the accompanying illustration.

## Sound Insulation Construction

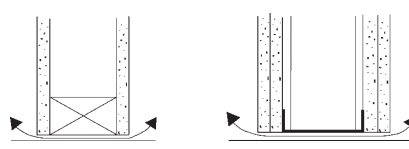
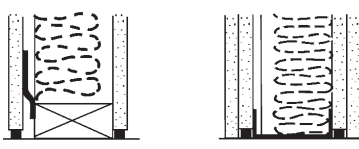
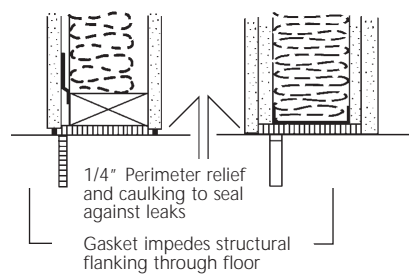
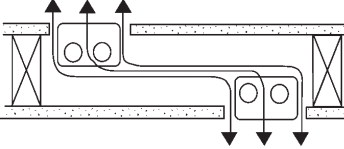
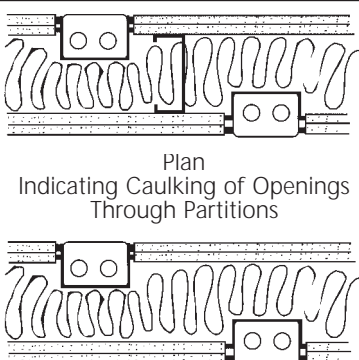
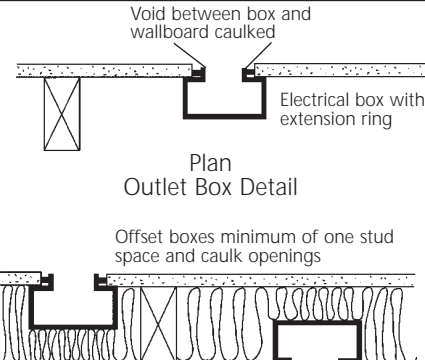
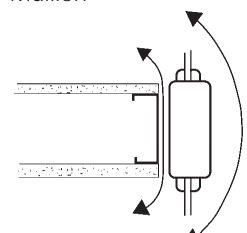
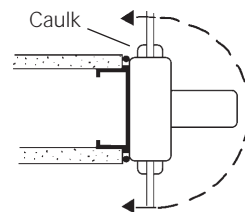
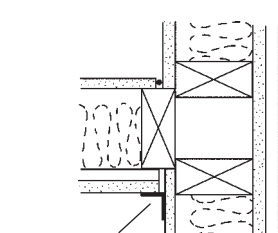
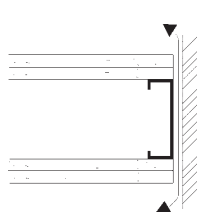
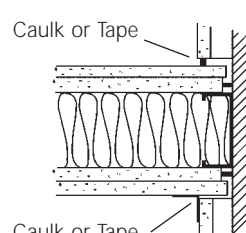
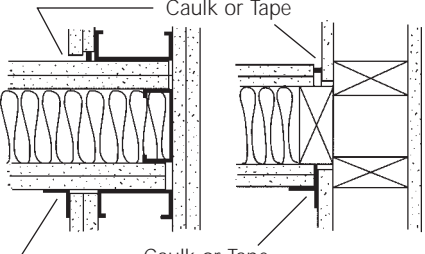
<p><b>“NORMAL CONSTRUCTION”</b> Not suitable for good sound control. Arrows show flanking paths</p>	<p><b>“SELECT CONSTRUCTION”</b> Caulking of relief detail at perimeter of partition to prevent sound leakage</p>	<p><b>“PRE-DESIGN” CONSTRUCTION</b> Simulating laboratory conditions</p>
 <p>Wood Stud System      Steel Stud System</p> <p>Elevation Under and Over Partitions</p>	 <p>Wood Stud      Metal Stud</p> <p>Elevation</p>	 <p>1/4" Perimeter relief and caulk to seal against leaks Gasket impedes structural flanking through floor</p> <p>Elevation Typical Floor-Ceiling or Roof Detail</p>
 <p>Plan Through Partitions, Openings, Outlet Boxes</p>	 <p>Plan Indicating Caulking of Openings Through Partitions</p>	 <p>Void between box and wallboard caulked Electrical box with extension ring</p> <p>Plan Outlet Box Detail</p> <p>Offset boxes minimum of one stud space and caulk openings</p>
<p>Window Mullion</p>  <p>Plan Around Flanking Partition Ends</p>	 <p>Plan Typical Partition Mullion Intersection</p>	 <p>Plan Intersection With Exterior Wall</p>
 <p>Plan Metal Stud Around Flanking Partition Ends</p>	 <p>Plan Intersection With Interior Wall</p>	 <p>Plan Typical Partition Intersections</p>

## DEFINITIONS

Definitions of "Fire Resistance Rating" and "STC" as used in this manual are as follows:

**Fire Resistance Rating:** The degree to which construction assemblies resist the passage of heat and flame is indicated by ratings determined by full scale fire resistance tests conducted in accordance with CAN/ULC-S101 or ASTM E 119.

**STC:** Sound Transmission Class, a single number which represents the overall performance of an assembly at all sound frequencies. As per ASTM E 90 and E 413, the higher the STC, the more efficient the system for reducing sound transmission.

## TESTING AUTHORITIES

Abbreviations for the testing authorities cited in this manual are as follows:

### Fire Resistance Ratings

NBCC	National Building Code of Canada
ULC	Underwriters' Laboratories of Canada
ITS	Intertek Testing Services (Formerly Warnock Hersey International)
ULI	Underwriters Laboratories Inc.
NRC	National Research Council, Canada

### Sound Ratings

NBCC	National Building Code of Canada
NRC	National Research Council, Canada
WHI	Warnock Hersey International (at the time of testing, now part of ITS)

## ESTIMATES

Not all of the assemblies in this catalogue have been individually tested. Where no specific test data is available, an estimated rating is provided for guidance only. CertainTeed Corporation makes no claim that these estimates comply with, or are acceptable under, any building code.

These estimates are based on a judgement of how the particular assembly might react, when compared with similar ones which have been tested in accordance with recognized standards.

If specific compliance is required, tests should be conducted.

## BUILDING CODES

Within Canada, Building Codes govern among other items, the type, use and application of construction materials. It is therefore important that the user, when determining the suitability of products and assemblies outlined in this manual, ensure that the requirements of the applicable Building Code(s) have been met.

## MATERIAL AND APPLICATION STANDARDS

Gypsum board products and many of the accessories that are utilized in the construction and/or finishing of gypsum board are covered by standards. These standards set forth minimum requirements for their physical and/or performance characteristics, limits of use and methods of application.

The following major Standards Writing Authorities are cited in this manual.

CSA Canadian Standards Association

CGSB Canadian General Standards Board

ASTM American Society for Testing and Materials

### **CertainTeed Corporation Materials**

---

CertainTeed Corporation gypsum board products are manufactured to meet or exceed the following standards.

#### **CertainTeed Corporation**

##### **Gypsum Board Product**

##### **Standard(s)**

---

ProRoc Regular + 54"	CAN/CSA-A82.27, ASTM C 1396 + C 36
ProRoc Type X + ProRoc Type C	CAN/CSA-A82.27, ASTM C 1396 + C 36
ProRoc Treated Core Sheathing	CAN/CSA-A82.27, ASTM C 1396 + C 79
ProRoc Moisture Resistant	CAN/CSA-A82.27, ASTM C 1396 + C 630
ProRoc Veneer Plaster Base	CAN/CSA-A82.27, ASTM C 1396 + C 588
ProRoc Interior Ceiling	CAN/CSA-A82.27, ASTM C 1395, C 1396 + C 36
ProRoc Vinyl Board	CAN/CSA-A82.27, ASTM C 1396 + C 960

---

#### **Accessory Materials**

The materials used in conjunction with CertainTeed Corporation gypsum board products should be manufactured to meet or exceed the following standards.

##### **Material**

##### **Standard(s)**

---

Steel Stud	CAN/CGSB-7.1, ASTM C 645
Steel Track	CAN/CGSB-7.1, ASTM C 645
Steel Furring Channel	CAN/CGSB-7.1, ASTM C 645
Wood Framing Members	CAN/CSA O141
Drywall Screws	ASTM C 1002
Drywall Nails	CSA B111, ASTM C 514
Adhesives	CGSB 71-GP-25M
Joint Compounds	ASTM C 475
Joint Tape	ASTM C 475
Gypsum Plaster	CAN/CSA-A82.22, ASTM C 28

---

#### **Application Standards**

NBCC National Building Code of Canada

CAN/CSA-A82.31 Gypsum Board Application

ASTM C 840 Application and Finishing of Gypsum Board

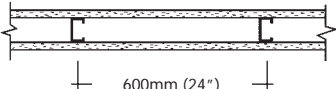
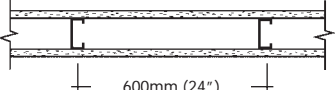
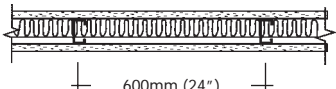
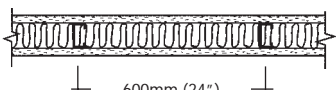
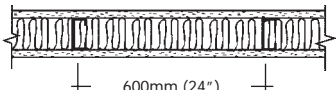
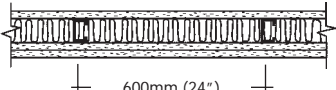
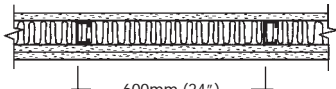

# STEEL STUD PARTITIONS

## Non-load bearing

SOUND TRANSMISSION CLASS (STC)	CONSTRUCTION	DESCRIPTION	DESIGN NUMBER/TEST REPORTS
<b>FIRE RESISTANCE RATING: 3/4h</b>			
35	 <p>Thickness: 95mm (3 3/4") Weight: 25 kg/m<sup>2</sup> (5.0 lb/ft<sup>2</sup>)</p>	<p><b>System WPB035</b> 15.9mm (5/8") ProRoc Type X, 1 layer, each side of 64mm (2 1/2") steel studs. Fasten boards vertically using 32mm (1 1/4") screws spaced 200mm (8") o.c. along floor and ceiling tracks, and 300mm (12") o.c. along edge joints and in the field. Joints must be offset. Tape and finish joints with ProRoc products.</p>	<p>FIRE: ULC W409 SOUND: NBCC (1995) Table A-9.10.3.1.A Wall S1c</p>
<b>FIRE RESISTANCE RATING: 1h</b>			
38	 <p>Thickness: 124mm (4 7/8") Weight: 25 kg/m<sup>2</sup> (5.1 lb/ft<sup>2</sup>)</p>	<p><b>System WPC138</b> 15.9mm (5/8") ProRoc Type X, 1 layer, each side of 92mm (3 5/8") steel studs. Fasten boards vertically using 25mm (1") screws spaced 200mm (8") o.c. along edge joints, floor and ceiling tracks, and 300mm (12") o.c. in the field. Joints must be offset. Tape and finish joints with ProRoc products.</p>	<p>FIRE: ULC W415 / ULI U465 SOUND: NBCC (1995) Table A-9.10.3.1.A Wall S4c</p>
43	 <p>Thickness: 89mm (3 1/2") Weight: 25 kg/m<sup>2</sup> (5.1 lb/ft<sup>2</sup>)</p>	<p><b>System WPB143</b> 12.7mm (1/2") ProRoc Type C, 1 layer, each side of 64mm (2 1/2") steel studs. Mineral wool insulation 38mm (1 1/2") within cavity. Fasten boards vertically using 25mm (1") screws spaced 200mm (8") o.c. along edge joints, floor and ceiling tracks, and 300mm (12") o.c. in the field. Joints must be offset. Tape and finish joints with ProRoc products.</p>	<p>FIRE: ULC W412 SOUND: NRC 795</p>
46	 <p>Thickness: 95mm (3 3/4") Weight: 26 kg/m<sup>2</sup> (5.4 lb/ft<sup>2</sup>)</p>	<p><b>System WPB146</b> 15.9mm (5/8") ProRoc Type X, 1 layer, each side of 64mm (2 1/2") steel studs. Glass fibre insulation 65mm (2 1/2") within cavity. Fasten boards vertically using 32mm (1 1/4") screws spaced 200mm (8") o.c. along floor and ceiling tracks, and 300mm (12") o.c. along edge joints and in the field. Joints must be offset. Tape and finish joints with ProRoc products.</p>	<p>FIRE: ULC W409 SOUND: NRC 804</p>
48	 <p>Thickness: 124mm (4 7/8") Weight: 27 kg/m<sup>2</sup> (5.5 lb/ft<sup>2</sup>)</p>	<p><b>System WPC148</b> 15.9mm (5/8") ProRoc Type X, 1 layer, each side of 92mm (3 5/8") steel studs. Glass fibre or mineral wool insulation 89mm (3 1/2") within cavity. Fasten boards vertically using 25mm (1") screws spaced 200mm (8") o.c. along edge joints, floor and ceiling tracks, and 300mm (12") o.c. in the field. Joints must be offset. Tape and finish joints with ProRoc products.</p>	<p>FIRE: Based on WPC 138 (ULC W415/ULI U465) SOUND: NRC 810</p>
50	 <p>Thickness: 102mm (4") Weight: 31 kg/m<sup>2</sup> (6.3 lb/ft<sup>2</sup>)</p>	<p><b>System WPB150</b> 12.7mm (1/2") ProRoc Type C, 1 layer on one side, 2 layers other side of 64mm (2 1/2") steel studs. Glass fibre or mineral wool insulation 65mm (2 1/2") within cavity. Fasten base layers vertically using 25mm (1") screws spaced 300mm (12") o.c. Fasten second layer vertically on one side using 41mm (1 5/8") screws spaced 300mm (12") o.c. Joints must be offset. Tape and finish outer layer joints with ProRoc products.</p>	<p>FIRE: NBCC (1995) Table A-9.10.3.1.A Wall S2c SOUND: NBCC (1995) Table A-9.10.3.1.A Wall S2c</p>
51	 <p>Thickness: 111mm (4 3/8") Weight: 38 kg/m<sup>2</sup> (7.8 lb/ft<sup>2</sup>)</p>	<p><b>System WPB151</b> 15.9mm (5/8") ProRoc Type X, 1 layer on one side, 2 layers other side of 64mm (2 1/2") steel studs. Glass fibre insulation 64mm (2 1/2") within cavity. Fasten base layers vertically using 32mm (1 1/4") screws spaced 200mm (8") o.c. along floor and ceiling tracks, and 300mm (12") o.c. along edge joints and in the field. Fasten second layer vertically on one side using 41mm (1 5/8") screws spaced 300mm (12") o.c. Joints must be offset. Tape and finish outer layer joints with ProRoc products.</p>	<p>FIRE: Based on WPB 146 (ULC W409) SOUND: NRC 805</p>

# STEEL STUD PARTITIONS

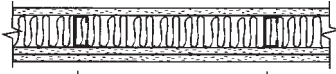
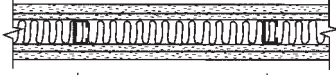
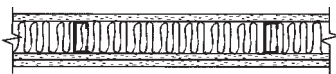
## Non-load bearing

SOUND TRANSMISSION CLASS (STC)	CONSTRUCTION	DESCRIPTION	DESIGN NUMBER/ TEST REPORTS
<b>FIRE RESISTANCE RATING: 1h (continued)</b>			
<b>51</b>	 <p style="text-align: center;">600mm (24")</p> <p>Thickness: 130mm (5 1/8") Weight: 31 kg/m<sup>2</sup> (6.4 lb/ft<sup>2</sup>)</p>	<p><b>System WPC151</b> 12.7mm (1/2") ProRoc Type C, 1 layer on one side, 2 layers other side of 92mm (3 5/8") steel studs. Glass fibre or mineral wool insulation 89mm (3 1/2") within cavity.</p> <p>Fasten base layers vertically using 25mm (1") screws spaced 300mm (12") o.c. Fasten second layer vertically on one side using 41mm (1 3/8") screws spaced 300mm (12") o.c. Joints must be offset. Tape and finish outer layer joints with ProRoc products.</p>	<p>FIRE: NBCC (1995) Table A-9.10.3.1.A Wall S5c / NRC 675</p> <p>SOUND: NBCC (1995) Table A-9.10.3.1.A Wall S5c</p>
<b>53</b>	 <p style="text-align: center;">600mm (24")</p> <p>Thickness: 108mm (4 1/4") Weight: 33 kg/m<sup>2</sup> (6.8 lb/ft<sup>2</sup>)</p>	<p><b>System WPB153</b> 12.7mm (1/2") ProRoc Type C, 1 layer, and 9.5mm (3/8") ProRoc Regular, 1 layer, each side of 64mm (2 1/2") steel studs. Glass fibre or mineral wool insulation 64mm (2 1/2") within cavity.</p> <p>Fasten 9.5mm (3/8") base layers vertically using 25mm (1") screws spaced 300mm (12") o.c. Laminate 12.7mm (1/2") face layers vertically using ProRoc Joint Compound and 32mm (1 1/4") screws spaced 200mm (8") o.c. along floor and ceiling track. Joints must be offset. Optional taping and finishing of outer layer joints with ProRoc products.</p>	<p>FIRE: ULC W402</p> <p>SOUND: BGL 691</p>
<b>53</b>	 <p style="text-align: center;">600mm (24")</p> <p>Thickness: 140mm (5 1/2") Weight: 38 kg/m<sup>2</sup> (7.8 lb/ft<sup>2</sup>)</p>	<p><b>System WPC153</b> 15.9mm (5/8") ProRoc Type X, 1 layer on one side, 2 layers other side of 92mm (3 5/8") steel studs. Glass fibre or mineral wool insulation 89mm (3 1/2") within cavity.</p> <p>Fasten base layers vertically using 25mm (1") screws spaced 200mm (8") o.c. along edge joints, and 300mm (12") o.c. in the field. Fasten second layer vertically or horizontally on one side using 41mm (1 3/8") screws spaced 300mm (12") o.c. Joints must be offset. Tape and finish outer layer joints with ProRoc products.</p>	<p>FIRE: Based on WPC138 (ULC W415/ULI U465)</p> <p>SOUND: NRC 811</p>
Recommended system for 1 hour fire rating and ≥ 50 STC.			
<b>55</b>	 <p style="text-align: center;">600mm (24")</p> <p>Thickness: 140mm (5 1/2") Weight: 29 kg/m<sup>2</sup> (6.0 lb/ft<sup>2</sup>)</p>	<p><b>System WCA155</b> 15.9mm (5/8") ProRoc Type X, 1 layer, each side of paired 41mm (1 3/8") steel studs. Glass fibre or mineral wool insulation 64mm (2 1/2") each side within cavity.</p> <p>Attach 15.9mm x 300mm (5/8" x 12") ProRoc Type X bridging 1200mm (48") o.c. to steel studs using screws (3 per stud). Fasten boards vertically using 25mm (1") screws spaced 200mm (8") o.c. along edge joints, floor and ceiling tracks, and 300mm (12") o.c. in the field. Joints must be offset. Tape and finish joints with ProRoc products.</p>	<p>FIRE: ULI U420</p> <p>SOUND: NRC-93-300</p>
<b>61</b>	 <p style="text-align: center;">600mm (24")</p> <p>Thickness: 156mm (6 1/8") Weight: 41 kg/m<sup>2</sup> (8.4 lb/ft<sup>2</sup>)</p>	<p><b>System WCA161</b> 15.9mm (5/8") ProRoc Type X, 1 layer on one side, 2 layers other side of paired 41mm (1 3/8") steel studs. Glass fibre or mineral wool insulation 64mm (2 1/2") each side within cavity.</p> <p>Attach 15.9mm x 300mm (5/8" x 12") ProRoc Type X bridging 1200mm (48") o.c. to steel studs using screws (3 per stud). Fasten base layers vertically using 25mm (1") screws spaced 200mm (8") o.c. along edge joints, and 300mm (12") o.c. in the field. Fasten second layer vertically or horizontally on one side using 41mm (1 3/8") screws spaced 300mm (12") o.c. Joints must be offset. Tape and finish outer layer joints with ProRoc products.</p>	<p>FIRE: Based on WCA155 (ULI U420)</p> <p>SOUND: NRC-93-301</p>

**NOTE:** For other high STC assemblies see 2 hour fire ratings

# STEEL STUD PARTITIONS

## Non-load bearing

SOUND TRANSMISSION CLASS (STC)	CONSTRUCTION	DESCRIPTION	DESIGN NUMBER/ TEST REPORTS
<b>FIRE RESISTANCE RATING: 2h</b>			
44	<p>Thickness: 114mm (4 1/2") Weight: 39 kg/m<sup>2</sup> (8.1 lb/ft<sup>2</sup>)</p>	<p><b>System WPB244</b> 12.7mm (1/2") ProRoc Type C, 2 layers, each side of 64mm (2 1/2") steel studs.</p> <p>Fasten base layers vertically using 25mm (1") screws spaced 300mm (12") o.c. Fasten face layers vertically using 41mm (1 3/8") screws spaced 300mm (12") o.c. Joints must be offset. Tape and finish outer layer joints with ProRoc products.</p>	<p>FIRE: ULC W414</p> <p>SOUND: NBCC (1995) Table A-9.10.3.1.A Wall S3i</p>
45	<p>Thickness: 127mm (5") Weight: 48 kg/m<sup>2</sup> (9.8 lb/ft<sup>2</sup>)</p>	<p><b>System WPB245</b> 15.9mm (5/8") ProRoc Type X, 2 layers, each side of 64mm (2 1/2") steel studs.</p> <p>Fasten base layers vertically using 25mm (1") screws spaced 300mm (12") o.c. Fasten face layers vertically using 41mm (1 3/8") screws spaced 300mm (12") o.c. Joints must be offset. Tape and finish outer layer joints with ProRoc products.</p>	<p>FIRE: ULC W414/ ULI U411</p> <p>SOUND: NBCC (1995) Table A-9.10.3.1.A Wall S3g</p>
53	<p>Thickness: 114mm (4 1/2") Weight: 41 kg/m<sup>2</sup> (8.4 lb/ft<sup>2</sup>)</p>	<p><b>System WPB253</b> 12.7mm (1/2") ProRoc Type C, 2 layers, each side of 64mm (2 1/2") steel studs. Glass fibre insulation 64mm (2 1/2") within cavity.</p> <p>Fasten base layers vertically using 25mm (1") screws spaced 300mm (12") o.c. Fasten face layers vertically using 41mm (1 3/8") screws spaced 300mm (12") o.c. Joints must be offset. Tape and finish outer layer joints with ProRoc products.</p>	<p>FIRE: Based on WPB244 (ULC W414)</p> <p>SOUND: NRC 798</p>
54	<p>Thickness: 171mm (6 3/4") Weight: 59 kg/m<sup>2</sup> (12 lb/ft<sup>2</sup>)</p>	<p><b>System WPC254</b> 15.9mm (5/8") ProRoc Type X, 3 layers on one side, 2 layers other side of 92mm (3 5/8") steel studs. No insulation.</p> <p>Fasten base layers vertically using 25mm (1") screws spaced 300mm (12") o.c. Fasten second layers vertically using 41mm (1 3/8") screws spaced 300mm (12") o.c. Fasten third layer vertically or horizontally on one side with 57mm (2 1/4") screws spaced 300mm (12") o.c. Joints must be offset. Tape and finish outer layer joints with ProRoc products.</p>	<p>FIRE: Based on WPB245 (ULC W414/ULI U411)</p> <p>SOUND: NRC TL-92-371</p>
54	<p>Thickness: 127mm (5") Weight: 49 kg/m<sup>2</sup> (10 lb/ft<sup>2</sup>)</p>	<p><b>System WPB254</b> 15.9mm (5/8") ProRoc Type X, 2 layers, each side of 64mm (2 1/2") steel studs. Glass fibre insulation 64mm (2 1/2") within cavity.</p> <p>Fasten base layers vertically using 25mm (1") screws spaced 300mm (12") o.c. Fasten face layers vertically using 41mm (1 3/8") screws spaced 300mm (12") o.c. Joints must be offset. Tape and finish outer layer joints with ProRoc products.</p>	<p>FIRE: Based on WPB245 (ULC W414/ULI U411)</p> <p>SOUND: NRC 806</p>
55	<p>Thickness: 143mm (5 5/8") Weight: 41 kg/m<sup>2</sup> (8.5 lb/ft<sup>2</sup>)</p>	<p><b>System WPC255</b> 12.7mm (1/2") ProRoc Type C, 2 layers, each side of 92mm (3 5/8") steel studs. Glass fibre insulation 89mm (3 1/2") within cavity.</p> <p>Fasten base layers vertically using 25mm (1") screws spaced 300mm (12") o.c. Fasten face layers vertically using 41mm (1 3/8") screws spaced 300mm (12") o.c. Joints must be offset. Tape and finish outer layer joints with ProRoc products.</p>	<p>FIRE: Based on WPB244 (ULC W414)</p> <p>SOUND: NRC 809</p>
56	<p>Thickness: 156mm (6 1/8") Weight: 50 kg/m<sup>2</sup> (10 lb/ft<sup>2</sup>)</p>	<p><b>System WPC256</b> 15.9mm (5/8") ProRoc Type X, 2 layers, each side of 92mm (3 5/8") steel studs. Glass fibre insulation 89mm (3 1/2") within cavity.</p> <p>Fasten base layers vertically using 25mm (1") screws spaced 300mm (12") o.c. Fasten face layers vertically using 41mm (1 3/8") screws spaced 300mm (12") o.c. Joints must be offset. Tape and finish outer layer joints with ProRoc products.</p>	<p>FIRE: Based on WPB245 (ULC W414/ULI U411)</p> <p>SOUND: NRC 812</p>

# STEEL STUD PARTITIONS

## Non-load bearing

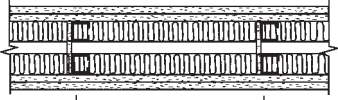
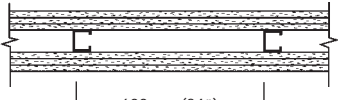
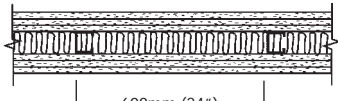
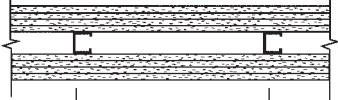
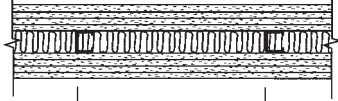
SOUND TRANSMISSION CLASS (STC)	CONSTRUCTION	DESCRIPTION	DESIGN NUMBER/TEST REPORTS
<b>FIRE RESISTANCE RATING: 2h (continued)</b>			
65	 <p data-bbox="220 537 456 590">Thickness: 172mm (6 3/4") Weight: 49 kg/m<sup>2</sup> (10 lb/ft<sup>2</sup>)</p>	<p data-bbox="599 386 797 415"><b>System WCA265</b></p> <p data-bbox="599 415 1263 468">15.9mm (5/8") ProRoc Type X, 2 layers, each side of paired 41mm (1 1/2") steel studs. Glass fibre or mineral wool insulation 64mm (2 1/2") each side within cavity.</p> <p data-bbox="599 478 1263 659">Attach 15.9mm x 300mm (5/8" x 12") ProRoc Type X bridging 1200mm (48") o.c. to steel studs using screws (3 per stud). Fasten base layers vertically using 25mm (1") screws spaced 200mm (8") o.c. along edge joints, floor and ceiling tracks, and 300mm (12") o.c. in the field. Fasten face layers vertically using 41mm (1 1/2") screws spaced 200mm (8") o.c. along edge joints, floor and ceiling tracks, and 300mm (12") o.c. in the field. Joints must be offset. Tape and finish outer layer joints with ProRoc products.</p>	<p data-bbox="1325 386 1438 407">FIRE: ULI U420</p> <p data-bbox="1325 436 1484 457">SOUND: NRC-93-321</p>
<b>FIRE RESISTANCE RATING: 3h</b>			
44	 <p data-bbox="220 884 456 926">Thickness: 118mm (4 5/8") Weight: 58 kg/m<sup>2</sup> (12 lb/ft<sup>2</sup>)</p>	<p data-bbox="599 747 792 777"><b>System WPA344</b></p> <p data-bbox="599 777 1263 968">12.7mm (1/2") ProRoc Type C, 3 layers, each side of 41mm (1 1/2") steel studs. Fasten base layers vertically using 25mm (1") screws spaced 300mm (12") o.c. Fasten second layers vertically using 41mm (1 1/2") screws spaced 300mm (12") o.c. Fasten third layers vertically or horizontally with 57mm (2 1/4") screws spaced 300mm (12") o.c. Note, for horizontal applications use 38mm (1 1/2") Type G screws along the horizontal edge and in the field between studs. Joints must be offset. Tape and finish outer layer joints with ProRoc products.</p>	<p data-bbox="1325 747 1451 768">FIRE: ULC W418</p> <p data-bbox="1325 798 1484 819">SOUND: NRC 1072</p>
52	 <p data-bbox="220 1148 456 1199">Thickness: 118mm (4 5/8") Weight: 60 kg/m<sup>2</sup> (12 lb/ft<sup>2</sup>)</p>	<p data-bbox="599 1020 792 1050"><b>System WPA352</b></p> <p data-bbox="599 1050 1263 1272">12.7mm (1/2") ProRoc Type C, 3 layers, each side of 41mm (1 1/2") steel studs. Mineral wool insulation 38mm (1 1/2") within cavity. Fasten base layers vertically using 25mm (1") screws spaced 300mm (12") o.c. Fasten second layers vertically using 41mm (1 1/2") screws spaced 300mm (12") o.c. Fasten third layers vertically or horizontally with 57mm (2 1/4") screws spaced 300mm (12") o.c. Note, for horizontal applications use 38mm (1 1/2") Type G screws along the horizontal edge and in the field between studs. Joints must be offset. Tape and finish outer layer joints with ProRoc products.</p>	<p data-bbox="1325 1020 1438 1071">FIRE: Based on WPA344</p> <p data-bbox="1325 1100 1484 1121">SOUND: NRC 1073</p>
<b>FIRE RESISTANCE RATING: 4h</b>			
49	 <p data-bbox="220 1503 456 1545">Thickness: 143mm (5 5/8") Weight: 77 kg/m<sup>2</sup> (16 lb/ft<sup>2</sup>)</p>	<p data-bbox="599 1367 792 1396"><b>System WPA449</b></p> <p data-bbox="599 1396 1263 1608">12.7mm (1/2") ProRoc Type C, 4 layers, each side of 41mm (1 1/2") steel studs. Fasten base layers vertically using 25mm (1") screws spaced 300mm (12") o.c. Fasten second layers vertically using 41mm (1 1/2") screws spaced 300mm (12") o.c. Fasten third layers vertically with 57mm (2 1/4") screws spaced 300mm (12") o.c. Fasten fourth layers vertically or horizontally with 67mm (2 5/8") screws spaced 300mm (12") o.c. Note, for horizontal applications use 38mm (1 1/2") Type G screws along the horizontal edge and in the field between studs. Joints must be offset. Tape and finish outer layer joints with ProRoc products.</p>	<p data-bbox="1325 1367 1451 1388">FIRE: ULC W418</p> <p data-bbox="1325 1417 1484 1438">SOUND: NRC 1075</p>
56	 <p data-bbox="220 1818 456 1860">Thickness: 143mm (5 5/8") Weight: 79 kg/m<sup>2</sup> (16 lb/ft<sup>2</sup>)</p>	<p data-bbox="599 1682 792 1711"><b>System WPA456</b></p> <p data-bbox="599 1711 1263 1944">12.7mm (1/2") ProRoc Type C, 4 layers, each side of 41mm (1 1/2") steel studs. Mineral wool insulation 38mm (1 1/2") within cavity. Fasten base layers vertically using 25mm (1") screws spaced 300mm (12") o.c. Fasten second layers vertically using 41mm (1 1/2") screws spaced 300mm (12") o.c. Fasten third layers vertically with 57mm (2 1/4") screws spaced 300mm (12") o.c. Fasten fourth layers vertically or horizontally with 67mm (2 5/8") screws spaced 300mm (12") o.c. Note, for horizontal applications use 38mm (1 1/2") Type G screws along the horizontal edge and in the field between studs. Joints must be offset. Tape and finish outer layer joints with ProRoc products.</p>	<p data-bbox="1325 1682 1438 1732">FIRE: Based on WPA449</p> <p data-bbox="1325 1753 1484 1774">SOUND: NRC 1074</p>

# STEEL STUD PARTITIONS

## Interior – Load bearing

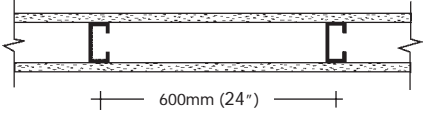
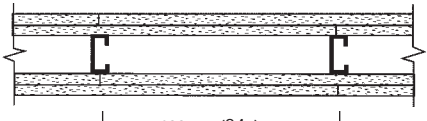
SOUND TRANSMISSION CLASS (STC)	CONSTRUCTION	DESCRIPTION	DESIGN NUMBER/ TEST REPORTS
<b>FIRE RESISTANCE RATING: 1h</b>			
32	 <p>Thickness: 121mm (4 3/4") Weight: 27 kg/m<sup>2</sup> (5.6 lb/ft<sup>2</sup>)</p>	<p><b>System WIBC132</b> 15.9mm (5/8") ProRoc Type X, 1 layer, each side of 89mm (3 1/2") 20 ga. load bearing steel studs.</p> <p>Fasten boards vertically using 25mm (1") screws spaced 300mm (12") o.c. Joints must be offset. Tape and finish joints with ProRoc products.</p>	<p>FIRE: ULI U425</p> <p>SOUND: NBCC (1995) Table A-9.10.3.1.A Wall S10b</p>
<b>FIRE RESISTANCE RATING: 2h</b>			
36	 <p>Thickness: 153mm (6") Weight: 50 kg/m<sup>2</sup> (10 lb/ft<sup>2</sup>)</p>	<p><b>System WIBC236</b> 15.9mm (5/8") ProRoc Type X, 2 layers, each side 89mm (3 1/2") 20 ga. load bearing steel studs.</p> <p>Fasten base layers vertically using 25mm (1") screws spaced 300mm (12") o.c. Fasten face layers vertically using 41mm (1 1/8") screws spaced 300mm (12") o.c. Joints must be offset. Tape and finish outer layer joints with ProRoc products.</p>	<p>FIRE: ULI U425</p> <p>SOUND: NBCC (1995) Table A-9.10.3.1.A Wall S11d</p>

# STEEL STUD PARTITIONS

## Exterior – Load bearing

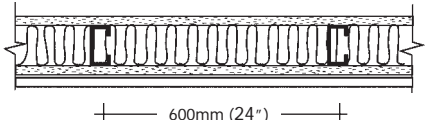
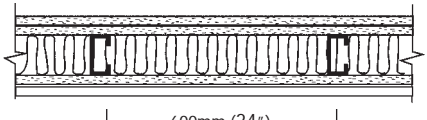
<b>FIRE RESISTANCE RATING: 3/4h</b>			
34	 <p>Thickness: 118mm (4 5/8") plus exterior finish Weight: 25 kg/m<sup>2</sup> (5.1 lb/ft<sup>2</sup>) plus exterior finish</p>	<p><b>System WEBC034</b> 15.9mm (5/8") ProRoc Type X, 1 layer, interior side, 12.7mm (1/2") ProRoc Treated Core Sheathing, 1 layer, exterior side of 89mm (3 1/2") 20 ga. load bearing steel studs. Thermal insulation, exterior finish.</p> <p>Fasten ProRoc Treated Core Sheathing vertically to the exterior side using 25mm (1") screws spaced 300mm (12") o.c. Fasten ProRoc Type X vertically to the interior side using 25mm (1") screws spaced 300mm (12") o.c. Joints must be offset. Tape and finish interior joints with ProRoc products.</p>	<p>FIRE: ULI U425</p> <p>SOUND: NBCC (1995) Table A-9.10.3.1.A Wall S10a</p>
<b>FIRE RESISTANCE RATING: 1-1/2h</b>			
38	 <p>Thickness: 134mm (5 1/4") plus exterior finish Weight: 36 kg/m<sup>2</sup> (7.4 lb/ft<sup>2</sup>) plus exterior finish</p>	<p><b>System WEBC138</b> 15.9mm (5/8") ProRoc Type X, 2 layers, interior side, 12.7mm (1/2") ProRoc Treated Core Sheathing, 1 layer, exterior side of 89mm (3 1/2") 20 ga. load bearing steel studs. Thermal insulation, exterior finish.</p> <p>Fasten ProRoc Treated Core Sheathing vertically to the exterior side using 25mm (1") screws spaced 300mm (12") o.c. Fasten base layer vertically to the interior side using 25mm (1") screws spaced 300mm (12") o.c. Fasten face layer vertically to the using 41mm (1 1/8") screws spaced 300mm (12") o.c. Joints must be offset. Tape and finish interior joints with ProRoc products.</p>	<p>FIRE: ULI U425</p> <p>SOUND: NBCC (1995) Table A-9.10.3.1.A Wall S11a</p>

# WOOD STUD PARTITIONS

## Load bearing

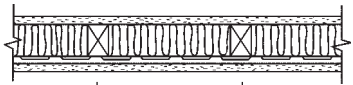
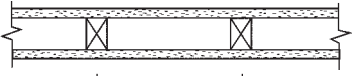
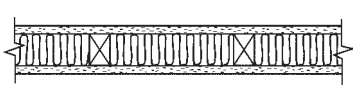
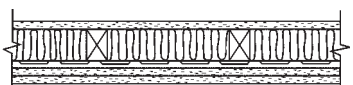
SOUND TRANSMISSION CLASS (STC)	CONSTRUCTION	DESCRIPTION	DESIGN NUMBER/ TEST REPORTS
<b>FIRE RESISTANCE RATING: 3/4h</b>			
<b>32</b> (with insulation STC 34)	 <p style="text-align: center;">+ 400mm (16") +</p> <p>Thickness: 114mm (4 1/2") Weight: 27 kg/m<sup>2</sup> (5.4 lb/ft<sup>2</sup>)</p>	<p><b>System WPE032</b> 12.7mm (1/2") ProRoc Type C, 1 layer, each side of 38mm x 89mm (2 x 4) wood studs.</p> <p>Fasten boards vertically using 44mm (1 3/4") nails spaced 175mm (7") o.c. Joints must be offset. Tape and finish joints with ProRoc products.</p>	<p>FIRE: ULC W302</p> <p>SOUND: NBCC (1995) Table A-9.10.3.1.A - Wall W1e</p>
<b>45</b>	 <p style="text-align: center;">+ 600mm (24") or 400mm (16") +</p> <p>Thickness: 133mm (5 1/4") Weight: 33 kg/m<sup>2</sup> (6.8 lb/ft<sup>2</sup>)</p>	<p><b>System WPE045</b> 15.9mm (5/8") ProRoc Type X, 1 layer on 38mm x 89mm (2 x 4) wood studs, one side on resilient channels. Glass fibre or mineral wool insulation 89mm (3 1/2") within cavity.</p> <p>Fasten board vertically or horizontally to one side with 41mm (1 1/2") screws spaced 300mm (12") o.c. Attach resilient channels with tabs downwards, horizontally at 400mm (16") or 600mm (24") o.c. to studs on opposite side with 32mm (1 1/4") screws. Upper channel 150mm (6") from top, lower channel 400mm (16") up from bottom and at the bottom of the partition, install an inverted channel. Fasten board vertically or horizontally to the resilient channels with 25mm (1") screws spaced 300mm (12") o.c. Joints must be offset. Tape and finish joints with ProRoc products.</p>	<p>FIRE: NBCC (1995) Table A-9.10.3.1.A Wall W3a</p> <p>SOUND: NBCC (1995) Table A-9.10.3.1.A Wall W3a</p>
<b>FIRE RESISTANCE RATING: 1h</b>			
<b>32</b> (with insulation STC 36)	 <p style="text-align: center;">+ 400mm (16") +</p> <p>Thickness: 121mm (4 3/4") Weight: 31 kg/m<sup>2</sup> (6.3 lb/ft<sup>2</sup>)</p>	<p><b>System WPE132</b> 15.9mm (5/8") ProRoc Type X, 1 layer, each side of 38mm x 89mm (2 x 4) wood studs.</p> <p>Fasten boards vertically using 51mm (2") nails spaced 175mm (7") o.c. Joints must be offset. Tape and finish joints with ProRoc products.</p>	<p>FIRE: ULC W301 (ULI U305)</p> <p>SOUND: NBCC (1995) Table A-9.10.3.1.A Wall W1d</p>
<b>34</b>	 <p style="text-align: center;">+ 600mm (24") or 400mm (16") +</p> <p>Thickness: 114mm (4 1/2") Weight: 30 kg/m<sup>2</sup> (6.2 lb/ft<sup>2</sup>)</p>	<p><b>System WPE134</b> 12.7mm (1/2") ProRoc Type C, 1 layer, each side of 38mm x 89mm (2 x 4) wood studs. Mineral wool insulation 89mm (3 1/2") within cavity.</p> <p>Fasten boards vertically using 32mm (1 1/4") screws spaced 300mm (12") o.c.; or 32mm (1 1/4") nails spaced 200mm (8") o.c. Joints must be offset. Tape and finish joints with ProRoc products.</p>	<p>FIRE: NBCC (1995) Table A-9.10.3.1.A Wall W1b</p> <p>SOUND: NBCC (1995) Table A-9.10.3.1.A Wall W1b</p>
<b>51</b>	 <p style="text-align: center;">+ 600mm (24") or 400mm (16") +</p> <p>Thickness: 149mm (5 7/8") Weight: 44 kg/m<sup>2</sup> (9.1 lb/ft<sup>2</sup>)</p>	<p><b>System WPE151</b> 15.9mm (5/8") ProRoc Type X, 1 layer, 1 side of 38mm x 89mm (2 x 4) wood studs. Other side, 2 layers on resilient channels. Glass fibre or mineral wool insulation 89mm (3 1/2") within cavity.</p> <p>Fasten board vertically or horizontally to one side with 41mm (1 1/2") screws spaced 300mm (12") o.c. Attach resilient channels with tabs downwards, horizontally at 400mm (16") or 600mm (24") o.c. to studs on opposite side with 32mm (1 1/4") screws. Upper channel 150mm (6") from top, lower channel 400mm (16") up from bottom and at the bottom of the partition, install an inverted channel. Fasten base layer vertically to the resilient channels with 25mm (1") screws spaced 300mm (12") o.c. Fasten face layer vertically or horizontally with 41mm (1 1/2") screws spaced 300mm (12") o.c. Joints must be offset. Tape and finish outer layer joints with ProRoc products.</p>	<p>FIRE: NBCC (1995) Table A-9.10.3.1.A Wall W4a</p> <p>SOUND: NBCC (1995) Table A-9.10.3.1.A Wall W4a</p>

# WOOD STUD PARTITIONS

## Load bearing

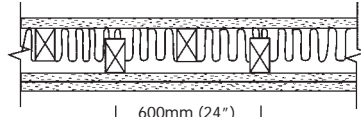
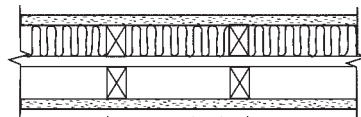
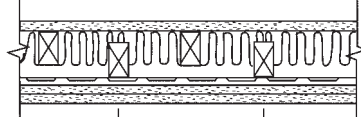
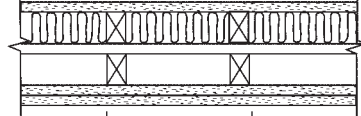
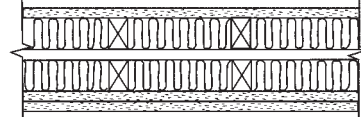
SOUND TRANSMISSION CLASS (STC)	CONSTRUCTION	DESCRIPTION	DESIGN NUMBER/ TEST REPORTS
<b>FIRE RESISTANCE RATING: 1h (continued)</b>			
<b>52</b>	 <p style="text-align: center;">600mm (24") or 400mm (16")</p> <p>Thickness: 187mm (7 3/8") Weight: 47 kg/m<sup>2</sup> (9.7 lb/ft<sup>2</sup>)</p>	<p><b>System WPE152</b> 15.9mm (5/8") ProRoc Type X, 1 layer, 1 side of staggered 38mm x 89mm (2 x 4) wood studs. Other side, 2 layers. Glass fibre or mineral wool insulation 89mm (3 1/2") within cavity.</p> <p>Fasten base layers vertically or horizontally using 41mm (1 1/2") screws spaced 300mm (12") o.c.; or 38mm (1 1/2") nails spaced 200mm (8") o.c. Fasten face layer to one side vertically or horizontally using 51mm (2") screws spaced 300mm (12") o.c.; or 51mm (2") nails spaced 200mm (8") o.c. Joints must be offset. Tape and finish outer layer joints with ProRoc products.</p>	<p>FIRE: NBCC (1995) Table A-9.10.3.1.A Wall W8a</p> <p>SOUND: NBCC (1995) Table A-9.10.3.1.A Wall W8a</p>
<b>54</b>	 <p style="text-align: center;">600mm (24") or 400mm (16")</p> <p>Thickness: 235mm (9 1/4") Weight: 42 kg/m<sup>2</sup> (8.6 lb/ft<sup>2</sup>)</p>	<p><b>System WPE154</b> 15.9mm (5/8") ProRoc Type X, 1 layer, each side of double row of 38mm x 89mm (2 x 4) wood studs. Glass fibre or mineral wool insulation 89mm (3 1/2") within cavity, 1 side.</p> <p>Set plates 25mm (1") apart. Fasten boards vertically or horizontally using 41mm (1 1/2") screws spaced 300mm (12") o.c.; or 38mm (1 1/2") nails spaced 200mm (8") o.c. Joints must be offset. Tape and finish joints with ProRoc products.</p>	<p>FIRE: NBCC (1995) Table A-9.10.3.1.A Wall W13c</p> <p>SOUND: NBCC (1995) Table A-9.10.3.1.A Wall W13c</p>
<b>56</b>	 <p style="text-align: center;">600mm (24") or 400mm (16")</p> <p>Thickness: 200mm (7 7/8") Weight: 47 kg/m<sup>2</sup> (9.7 lb/ft<sup>2</sup>)</p>	<p><b>System WPE156</b> 15.9mm (5/8") ProRoc Type X, 1 layer, 1 side of staggered 38mm x 89mm (2 x 4) wood studs. Other side, 2 layers on resilient channels. Glass fibre or mineral wool insulation 89mm (3 1/2") within cavity.</p> <p>Fasten board vertically or horizontally to one side with 41mm (1 1/2") screws spaced 300mm (12") o.c. Attach resilient channels with tabs downwards, horizontally at 400mm (16") or 600mm (24") o.c. to studs on opposite side with 32mm (1 1/4") screws. Upper channel 150mm (6") from top, lower channel 400mm (16") up from bottom and at the bottom of the partition, install an inverted channel. Fasten base layer vertically to the resilient channels with 25mm (1") screws spaced 300mm (12") o.c. Fasten face layer vertically or horizontally with 41mm (1 1/2") screws spaced 300mm (12") o.c. Joints must be offset. Tape and finish outer layer joints with ProRoc products.</p>	<p>FIRE: NBCC (1995) Table A-9.10.3.1.A Wall W11a</p> <p>SOUND: NBCC (1995) Table A-9.10.3.1.A Wall W11a</p>
<b>57</b>	 <p style="text-align: center;">600mm (24") or 400mm (16")</p> <p>Thickness: 251mm (9 7/8") Weight: 53 kg/m<sup>2</sup> (10.9 lb/ft<sup>2</sup>)</p>	<p><b>System WPE157</b> 15.9mm (5/8") ProRoc Type X, 1 layer, 1 side of double row of 38mm x 89mm (2 x 4) wood studs. Other side, 2 layers. Glass fibre or mineral wool insulation 89mm (3 1/2") within cavity, 1 side.</p> <p>Set plates 25mm (1") apart. Fasten base layers vertically or horizontally using 41mm (1 1/2") screws spaced 300mm (12") o.c.; or 38mm (1 1/2") nails spaced 200mm (8") o.c. Fasten face layer to one side vertically or horizontally using 51mm (2") screws spaced 300mm (12") o.c.; or 51mm (2") nails spaced 200mm (8") o.c. Joints must be offset. Tape and finish outer layer joints with ProRoc products.</p>	<p>FIRE: NBCC (1995) Table A-9.10.3.1.A Wall W14c</p> <p>SOUND: NBCC (1995) Table A-9.10.3.1.A Wall W14c</p>
<b>61</b>	 <p style="text-align: center;">600mm (24") or 400mm (16")</p> <p>Thickness: 251mm (9 7/8") Weight: 56 kg/m<sup>2</sup> (11.4 lb/ft<sup>2</sup>)</p>	<p><b>System WPE161</b> 15.9mm (5/8") ProRoc Type X, 1 layer, 1 side of double row 38mm x 89mm (2 x 4) wood studs. Other side, 2 layers. Glass fibre or mineral wool insulation 89mm (3 1/2") within cavity, both sides.</p> <p>Set plates 25mm (1") apart. Fasten base layers vertically or horizontally using 41mm (1 1/2") screws spaced 300mm (12") o.c.; or 38mm (1 1/2") nails spaced 200mm (8") o.c. Fasten face layer to one side vertically or horizontally using 51mm (2") screws spaced 300mm (12") o.c.; or 51mm (2") nails spaced 200mm (8") o.c. Joints must be offset. Tape and finish outer layer joints with ProRoc products.</p>	<p>FIRE: NBCC (1995) Table A-9.10.3.1.A Wall W14a</p> <p>SOUND: NBCC (1995) Table A-9.10.3.1.A Wall W14a</p>

\* Note: For other high STC assemblies see 1 1/2 and 2 hour fire ratings.

# WOOD STUD PARTITIONS

## Load bearing

SOUND TRANSMISSION CLASS (STC)	CONSTRUCTION	DESCRIPTION	DESIGN NUMBER/TEST REPORTS
--------------------------------	--------------	-------------	----------------------------

### FIRE RESISTANCE RATING: 1-1/2h (continued)

**58**

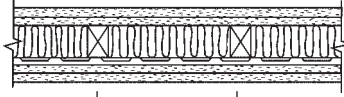

↓ 600mm (24")  
 or 400mm (16") ↓

Thickness: 165mm (6 1/2")  
Weight: 56 kg/m<sup>2</sup> (11.5 lb/ft<sup>2</sup>)

**System WPE158**  
15.9mm (5/8") ProRoc Type X, 2 layers, 1 side 38mm x 89mm (2 x 4) wood studs. Other side, 2 layers on resilient channels. Glass fibre or mineral wool insulation 89mm (3 1/2") within cavity.

Fasten base layer vertically or horizontally to one side with 41mm (1 5/8") screws spaced 300mm (12") o.c. Fasten face layer vertically or horizontally with 51mm (2") screws spaced 300mm (12") o.c. Attach resilient channels with tabs down, horizontally at 600mm (24") o.c. to studs on opposite side with 32mm (1 1/4") screws. Upper channel 150mm (6") from top, lower channel 600mm (24") up from bottom and at the bottom of the partition, install an inverted channel. Fasten base layer vertically to the resilient channels with 25mm (1") screws spaced 300mm (12") o.c. Fasten face layer vertically or horizontally with 41mm (1 5/8") screws spaced 300mm (12") o.c. Joints must be offset. Tape and finish outer layer joints with ProRoc products.

FIRE: NBCC (1995)  
Table A-9.10.3.1.A  
Wall W6b

SOUND: NBCC (1995)  
Table A-9.10.3.1.A  
Wall W6b

**62**

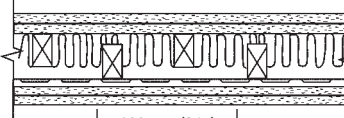

↓ 600mm (24")  
 or 400mm (16") ↓

Thickness: 216mm (8 1/2")  
Weight: 59 kg/m<sup>2</sup> (12 lb/ft<sup>2</sup>)

**System WPE162**  
15.9mm (5/8") ProRoc Type X, 2 layers, 1 side of staggered 38mm x 89mm (2 x 4) wood studs. Other side, 2 layers on resilient channels. Glass fibre or mineral wool insulation 89mm (3 1/2") within cavity.

Fasten base layer vertically or horizontally to one side with 41mm (1 5/8") screws spaced 300mm (12") o.c. Fasten face layer vertically or horizontally with 51mm (2") screws spaced 300mm (12") o.c. Attach resilient channels with tabs down, horizontally at 400mm (16") o.c. or 600mm (24") o.c. to studs on opposite side with 32mm (1 1/4") screws. Upper channel 150mm (6") from top, lower channel 400mm (16") up from bottom and at the bottom of the partition, install an inverted channel. Fasten base layer vertically to the resilient channels with 25mm (1") screws spaced 300mm (12") o.c. Fasten face layer vertically or horizontally with 41mm (1 5/8") screws spaced 300mm (12") o.c. Joints must be offset. Tape and finish outer layer joints with ProRoc products.

FIRE: NBCC (1995)  
Table A-9.10.3.1.A  
Wall W10a

SOUND: NBCC (1995)  
Table A-9.10.3.1.A  
Wall W10a

### FIRE RESISTANCE RATING: 2h

**36**  
(with insulation STC 38)

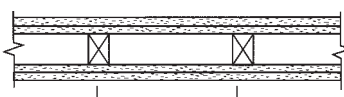

↓ 400mm (16") ↓

Thickness: 152mm (6")  
Weight: 54 kg/m<sup>2</sup> (11 lb/ft<sup>2</sup>)

**System WPE236**  
15.9mm (5/8") ProRoc Type X, 2 layers, each side of 38mm x 89mm (2 x 4) wood studs.

Fasten base layers vertically or horizontally using 48mm (1 7/8") nails spaced 150mm (6") o.c. Fasten face layers vertically or horizontally using 60mm (2 3/8") nails spaced 200mm (8") o.c. Joints must be offset. Tape and finish outer layer joints with ProRoc products.

FIRE: ULI U301

SOUND: NBCC (1995)  
Table A-9.10.3.1.A  
Wall W2d

**56**

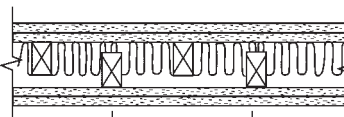

↓ 400mm (16") ↓

Thickness: 203mm (8")  
Weight: 59 kg/m<sup>2</sup> (12 lb/ft<sup>2</sup>)

**System WPE256**  
15.9mm (5/8") ProRoc Type X, 2 layers, each side of staggered 38mm x 89mm (2 x 4) wood studs. Glass fibre or mineral wool insulation 89mm (3 1/2") within cavity.

Fasten base layers vertically or horizontally using 48mm (1 7/8") nails spaced 150mm (6") o.c. Fasten face layers vertically or horizontally using 60mm (2 3/8") nails spaced 200mm (8") o.c. Joints must be offset. Tape and finish outer layer joints with ProRoc products.

FIRE: Based on WPE236 (ULI U301)

SOUND: NBCC (1995)  
Table A-9.10.3.1.A  
Wall W9a

**62**

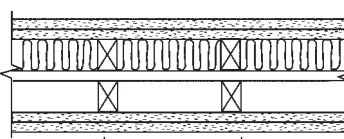

↓ 400mm (16") ↓

Thickness: 267mm (10 1/2")  
Weight: 65 kg/m<sup>2</sup> (13.2 lb/ft<sup>2</sup>)

**System WPE262**  
15.9mm (5/8") ProRoc Type X, 2 layers, each side of double row of 38mm x 89mm (2 x 4) wood studs. Glass fibre or mineral wool insulation 89mm (3 1/2") within cavity, 1 side.

Set plates 25mm (1") apart. Fasten base layers vertically or horizontally using 48mm (1 7/8") nails spaced 150mm (6") o.c. Fasten face layers vertically or horizontally using 60mm (2 3/8") nails spaced 200mm (8") o.c. Joints must be offset. Tape and finish outer layer joints with ProRoc products.

FIRE: Based on WPE236 (ULI U301)

SOUND: NBCC (1995)  
Table A-9.10.3.1.A  
Wall W15d

# WOOD STUD PARTITIONS

## Load bearing

SOUND TRANSMISSION CLASS (STC)	CONSTRUCTION	DESCRIPTION	DESIGN NUMBER/ TEST REPORTS
--------------------------------	--------------	-------------	-----------------------------

### FIRE RESISTANCE RATING: 2h (continued)

**66**

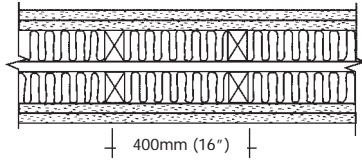

Thickness: 267mm (10 1/2")  
Weight: 67 kg/m<sup>2</sup> (13.7 lb/ft<sup>2</sup>)

#### System WPE266

15.9mm (5/8") ProRoc Type X, 2 layers, each side of double row of 38mm x 89mm (2 x 4) wood studs. Glass fibre or mineral wool insulation 89mm (3 1/2") within cavity, both sides.

Set plates 25mm (1") apart. Fasten base layers vertically or horizontally using 48mm (1 1/2") nails spaced 150mm (6") o.c. Fasten face layers vertically or horizontally using 60mm (2 3/8") nails spaced 200mm (8") o.c. Joints must be offset. Tape and finish outer layer joints with ProRoc products.

FIRE: Based on WPE236 (ULI U301)

SOUND: NBCC (1995) Table A-9.10.3.1.A Wall W15a

## ProRoc “J” Track, “I” Stud and Shaftliner Framing Installation

Lay out per construction drawings. Secure “J” track as perimeter framing on all sides, top and bottom, with suitable fasteners spaced 600mm (24”) o.c. maximum.

Pre-plan stud layout 600mm (24”) o.c. maximum so the terminal stud on either end will fall 200mm (8”) minimum from the end of the opening.

Erect the first 19mm (3/4”) ProRoc Shaftliner panel by inserting between the flanges of the “J” track at the top and bottom at one end of the opening. Plumb the panel flush against the web of “J” track sections at the end of the opening.

Secure with 32mm (1 1/4”) type S screws 600mm (24”) o.c. to the flange at the end of the opening, starting 150mm (6”) from the top or bottom. No screws are required at the top or bottom “J” tracks.

Fit an “I” stud to the Shaftliner making sure it’s engaged in the “J” track at the top and bottom.

Erect the adjacent Shaftliner panel by inserting in the top and bottom “J” track and the previously installed stud. Install succeeding studs and Shaftliner panels in this manner to complete the framing. Screws are not required for the top and bottom “J” tracks except at the ends of the opening, as described.

For doors, ducts or other openings install “J” track as perimeter framing.

When required for higher STC ratings, insulation should be friction fitted in the cavity before finishing on the cavity side with 15.9mm (5/8”) ProRoc Type X. Resilient channels may be attached horizontally 600mm (24”) o.c. to the studs with 10mm (3/8”) pan head screws at each stud.

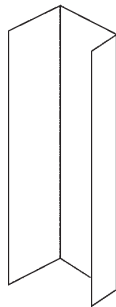

### “J” TRACK

57mm (2 1/4”) x 25mm (1”) LEGS x  
57mm (2 1/4”), 102mm (4”) OR  
152mm (6”) DEEP  
25 ga OR 20 ga

### “I” STUD

38mm (1 1/2”) WIDE  
x 57mm (2 1/4”), 102mm (4”)  
OR 152mm (6”) DEEP  
25 ga OR 20 ga

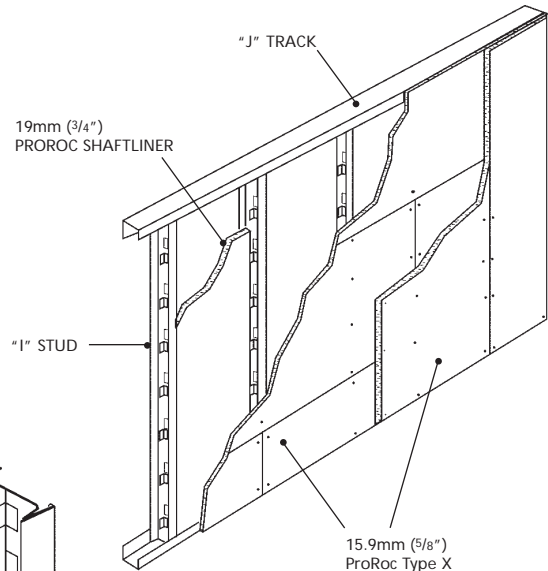
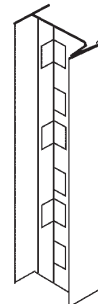

Illustrated with 2-Hour Fire Rating

### Helpful Hints

1. Use a fastening plate to secure the “J” track whenever fasteners are closer than 100mm (4”) to the edge. Setting the plate at the time of concrete construction will avoid spalling by mechanical fasteners.
2. Pre-cut “I” studs 13mm (1/2”) less than the height of the opening.
3. Pre-cut 19mm (3/4”) ProRoc Shaftliner panels 25mm (1”) less than the height of the opening.
4. In structural steel frame construction, install “J” track sections before applying spray-on fireproofing.
5. Items to be anchored to the wall (cabinets, sinks, handrails, etc.) should be fastened to the “I” studs or to plates secured behind or between the layers of 15.9mm (5/8”) ProRoc Type X.
6. Joint compounds should be applied at ambient temperatures above 10°C (50°F). Provide adequate ventilation to “drive-off” excess moisture.
7. For acoustic sealant and prevention of air leakage, use a bead of flexible caulking at the perimeter of each wall under the face layer of 15.9mm (5/8”) ProRoc Type X and under the 57mm (2 1/4”) flange of “J” track for shaftwall finished on one side.
8. Use type S screws for 25 ga steel framing. Use type S-12 screws for 20 ga or heavier steel framing.

## Recommended procedure for location of Gypsum Board Joints

ProRoc Shaftliner panels may be abutted (spliced) to span the floor-ceiling height. The shorter panel should be at least 600mm (24") long or of sufficient length to engage at least two "I" stud tabs on each panel edge. Succeeding butt joints between adjoining panels should be spaced no closer than 600mm (24") in elevation.

As an option, and as required in some building code jurisdictions, butt joints in Shaftliner panels may be back blocked in the cavity by screw-attaching a 300mm x 600mm (12" x 24") piece of ProRoc Shaftliner or 15.9mm (5/8") ProRoc Type X over the joint to the tabs of the "I" studs.

### First Layer

The first layer of 15.9mm (5/8") ProRoc Type X should be installed with horizontal joints offset a minimum of 300mm (12") from any butt joint in the ProRoc Shaftliner. Any vertical butt joints in the first layer should be staggered in 1200mm (48") increments between succeeding courses. In addition, joints must be offset from joints on opposite side.

### Second Layer

The second layer of 15.9mm (5/8") ProRoc Type X should be installed with vertical joints offset 600mm (24") from any vertical butt joints in the first layer. Any horizontal butt joints in the second layer should be offset a minimum of 300mm (12") from any horizontal joints in the first layer and from any butt joints in the ProRoc Shaftliner. Succeeding butt joints in the second layer between adjoining panels should be spaced no closer than 600mm (24") in elevation.

### Third Layer

The third layer of 15.9mm (5/8") ProRoc Type X should be installed with vertical joints offset 600mm (24") from any vertical joints in the second layer. Any horizontal butt joints in the third layer should be offset a minimum of 150mm

(6") from any horizontal joint in the previous layer, including ProRoc Shaftliner. Succeeding butt joints in the third layer between adjoining panels should be spaced no closer than 300mm (12") in elevation.

### Fourth Layer

The fourth layer of 15.9mm (5/8") ProRoc Type X should be installed to the resilient butt channels with vertical joints offset 300mm (12") from the studs. Any horizontal butt joints in the fourth layer should be centered over resilient channels and staggered between adjoining panels.

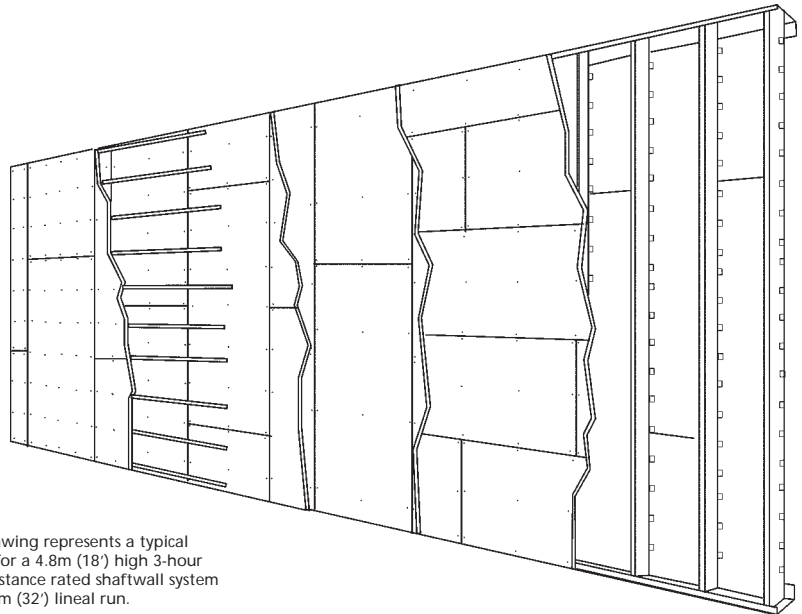

This drawing represents a typical layout for a 4.8m (18') high 3-hour fire resistance rated shaftwall system in a 9.8m (32') lineal run.

# SHAFTWALLS

## Non-load bearing

# STRUCTURAL DETAILS 1

## Limiting Heights

\* NOTE: Track Gauge must correspond to Stud Gauge indicated. Structural tests were conducted according to procedures in ASTM E 72. Some limiting height data are based on extrapolations and interpolations of similar tested assemblies in accordance with accepted engineering practices.

STUD DEPTH	STUD OR TRACK GAUGE *	DEFLECTION LIMITS	SUSTAINED AIR PRESSURE LOAD kPa (lb/ft <sup>2</sup> ) (The NBCC requires a design load of 0.5 kPa for walls acting as guards)								
			0.25 (5)		0.37 (7.5)		0.50 (10)		0.75 (15)		
			mm	ft	mm	ft	mm	ft	mm	ft	
<b>FIRE RESISTANCE RATING: 1h</b>											
57mm (2 1/4")	25 ga	L/120	3860	12'8"	3380	11'1"	3070	10'1"	2670	8'9"	
		L/240	3070	10'1"	2670	8'9"	2440	8'0"	2130	7'0"	
		L/360	2670	8'9"	2340	7'8"	2130	7'0"	1850	6'1"	
	20 ga	L/120	4520	14'10"	3940	12'11"	3580	11'9"	3120	10'3"	
		L/240	3580	11'9"	3120	10'3"	2850	9'4"	2490	8'2"	
		L/360	3120	10'3"	2740	9'0"	2490	8'2"	2160	7'1"	
101mm (4")	25 ga	L/120	5130	16'10"	4470	14'8"	4060	13'4"	3560	11'8"	
		L/240	4060	13'4"	3560	11'8"	3230	10'7"	2820	9'3"	
		L/360	3560	11'8"	3100	10'2"	2820	9'3"	2460	8'1"	
	20 ga	L/120	6150	20'2"	5390	17'8"	4880	16'0"	4270	14'0"	
		L/240	4880	16'0"	4270	14'0"	3890	12'9"	3380	11'1"	
		L/360	4270	14'0"	3730	12'3"	3380	11'1"	2950	9'8"	
152mm (6")	20 ga	L/120	7520	24'8"	6580	21'7"	5970	19'7"	5210	17'1"	
		L/240	5970	19'7"	5210	17'1"	4720	15'6"	4140	13'7"	
		L/360	5210	17'1"	4550	14'11"	4140	13'7"	3610	11'10"	
	<b>FIRE RESISTANCE RATING: 2h</b>										
	57mm (2 1/4")	25 ga	L/120	4170	13'8"	3630	11'11"	3300	10'10"	2900	9'6"
			L/240	3300	10'10"	2900	9'6"	2670	8'9"	2290	7'6"
L/360			2900	9'6"	2540	8'4"	2290	7'6"	2010	6'7"	
20 ga		L/120	4670	15'4"	4090	13'5"	3710	12'2"	3250	10'8"	
		L/240	3710	12'2"	3250	10'8"	2950	9'8"	2570	8'5"	
		L/360	3250	10'8"	2820	9'3"	2570	8'5"	2240	7'4"	
101mm (4")	25 ga	L/120	5540	18'2"	4830	15'10"	4400	14'5"	3840	12'7"	
		L/240	4390	14'5"	3840	12'7"	3480	11'5"	3050	10'0"	
		L/360	3840	12'7"	3350	11'0"	3050	10'0"	2670	8'9"	
	20 ga	L/120	6660	21'10"	5820	19'1"	5280	17'4"	4600	15'1"	
		L/240	5280	17'4"	4600	15'1"	4190	13'9"	3660	12'0"	
		L/360	4600	15'1"	4010	13'2"	3660	12'0"	3200	10'6"	
152mm (6")	20 ga	L/120	7700	25'3"	6730	22'1"	6120	20'1"	5330	17'6"	
		L/240	6120	20'1"	5330	17'6"	4850	15'11"	4240	13'11"	
		L/360	5330	17'6"	4670	15'4"	4240	13'11"	3710	12'2"	
	<b>FIRE RESISTANCE RATING: 3h</b>										
	57mm (2 1/4")	25 ga	L/120	4600	15'1"	4010	13'2"	3630	11'11"	3180	10'5"
			L/240	3630	11'11"	3180	10'5"	2900	9'6"	2520	8'3"
L/360			3180	10'5"	2770	9'1"	2520	8'3"	2210	7'3"	
101mm (4")		20 ga	L/120	5280	17'4"	4620	15'2"	4190	13'9"	3660	12'0"
			L/240	4190	13'9"	3660	12'0"	3330	10'11"	2920	9'7"
			L/360	3660	12'0"	3200	10'6"	2920	9'7"	2540	8'4"
	25 ga	L/120	6100	20'0"	5330	17'6"	4830	15'10"	4220	13'10"	
		L/240	4830	15'10"	4220	13'10"	3840	12'7"	3350	11'0"	
		L/360	4220	13'10"	3680	12'1"	3350	11'0"	2920	9'7"	
152mm (6")	20 ga	L/120	7320	24'0"	6380	20'11"	5790	19'0"	5080	16'8"	
		L/240	5790	19'0"	5080	16'8"	4600	15'1"	4010	13'2"	
		L/360	5080	16'8"	4420	14'6"	4010	13'2"	3510	11'6"	
	20 ga	L/120	8080	26'6"	7040	23'1"	6400	21'0"	5590	18'4"	
		L/240	6400	21'0"	5590	18'4"	5080	16'8"	4450	14'7"	
		L/360	5590	18'4"	4880	16'0"	4450	14'7"	3890	12'9"	

# SHAFTWALLS

## Non-load bearing

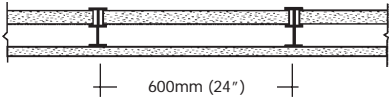
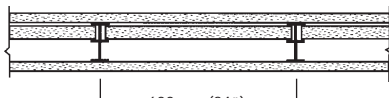
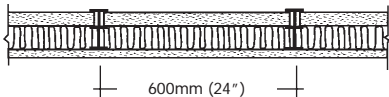
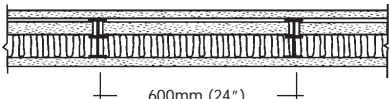
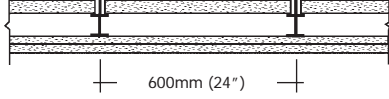
SOUND TRANSMISSION CLASS (STC)	CONSTRUCTION	DESCRIPTION	DESIGN NUMBER/ TEST REPORTS
<b>FIRE RESISTANCE RATING: 1h</b>			
<b>35</b>	 <p data-bbox="228 512 467 558">Thickness: 73mm (2 7/8") Weight: 28 kg/m<sup>2</sup> (5.6 lb/ft<sup>2</sup>)</p>	<p data-bbox="597 394 997 445"><b>System WSD135</b> <i>Finished one side.</i> 15.9mm (5/8") ProRoc Type X, 1 layer, corridor side.</p> <p data-bbox="597 457 1279 613">Install ProRoc J-track, I-stud and ProRoc Shaftliner panels in accordance with SHAFTWALL FRAMING DETAILS 1. Fasten board horizontally to corridor side with 25mm (1") screws spaced 300mm (12") o.c. starting 75mm (3") from the top of each I-stud. Screws are not required along top or bottom tracks. Joints must be offset in accordance with SHAFTWALL FRAMING DETAILS 2. Tape and finish corridor joints with ProRoc products.</p>	<p data-bbox="1328 394 1455 445">FIRE: ITS BPBC/WA 60-01</p> <p data-bbox="1328 470 1455 491">SOUND: WHI F7</p>
<b>41</b>	 <p data-bbox="228 768 467 814">Thickness: 86mm (3 3/8") Weight: 36 kg/m<sup>2</sup> (7.5 lb/ft<sup>2</sup>)</p>	<p data-bbox="597 651 1016 701"><b>System WSD141</b> <i>Finished both sides.</i> 15.9mm (5/8") ProRoc Type X, 1 layer, corridor side.</p> <p data-bbox="597 714 1279 924">Install ProRoc J-track, I-stud and ProRoc Shaftliner panels in accordance with SHAFTWALL FRAMING DETAILS 1. Fasten ProRoc Type X boards horizontally to corridor side with 25mm (1") screws spaced 300mm (12") o.c. starting 75mm (3") from the top of each I-stud. Fasten 12.7mm (1/2") ProRoc Regular boards vertically to the shaft side with (1") screws spaced 300mm (12") o.c. starting 75mm (3") from the top of each I-stud. Screws are not required along top or bottom tracks. Joints must be offset in accordance with SHAFTWALL FRAMING DETAILS 2. Tape and finish outer layer joints with ProRoc products.</p>	<p data-bbox="1328 651 1490 726">FIRE: Based on WSD 135 (ITS BPBC/WA 60-01)</p> <p data-bbox="1328 747 1490 802">SOUND: Based on WSD241</p>
<b>42</b>	 <p data-bbox="228 1071 467 1117">Thickness: 73mm (2 7/8") Weight: 28 kg/m<sup>2</sup> (5.8 lb/ft<sup>2</sup>)</p>	<p data-bbox="597 966 997 1016"><b>System WSD142</b> <i>Finished one side.</i> 15.9mm (5/8") ProRoc Type X, 1 layer, corridor side. Insulation within cavity.</p> <p data-bbox="597 1029 1279 1188">Install ProRoc J-track, I-stud and ProRoc Shaftliner panels in accordance with SHAFTWALL FRAMING DETAILS 1. Fasten board horizontally to corridor side with 25mm (1") screws spaced 300mm (12") o.c. starting 75mm (3") from the top of each I-stud. Screws are not required along top or bottom tracks. Joints must be offset in accordance with SHAFTWALL FRAMING DETAILS 2. Tape and finish corridor joints with ProRoc products.</p>	<p data-bbox="1328 966 1490 1041">FIRE: Based on WSD 135 (ITS BPBC/WA 60-01)</p> <p data-bbox="1328 1062 1455 1092">SOUND: WHI F8</p>
<b>48</b>	 <p data-bbox="228 1339 467 1386">Thickness: 86mm (3 3/8") Weight: 37 kg/m<sup>2</sup> (7.5 lb/ft<sup>2</sup>)</p>	<p data-bbox="597 1230 1016 1281"><b>System WSD148</b> <i>Finished both sides.</i> 15.9mm (5/8") ProRoc Type X, 1 layer, corridor side. Insulation within cavity.</p> <p data-bbox="597 1293 1279 1503">Install ProRoc J-track, I-stud and ProRoc Shaftliner panels in accordance with SHAFTWALL FRAMING DETAILS 1. Fasten ProRoc Type X boards horizontally to corridor side with 25mm (1") screws spaced 300mm (12") o.c. starting 75mm (3") from the top of each I-stud. Fasten 12.7mm (1/2") ProRoc Regular boards vertically to the shaft side with (1") screws spaced 300mm (12") o.c. starting 75mm (3") from the top of each I-stud. Screws are not required along top or bottom tracks. Joints must be offset in accordance with SHAFTWALL FRAMING DETAILS 2. Tape and finish outer layer joints with ProRoc products.</p>	<p data-bbox="1328 1230 1490 1306">FIRE: Based on WSD 135 (ITS BPBC/WA 60-01)</p> <p data-bbox="1328 1327 1490 1381">SOUND: Based on WSD248</p>
<b>FIRE RESISTANCE RATING: 2h</b>			
<b>40</b>	 <p data-bbox="228 1730 467 1776">Thickness: 89mm (3 1/2") Weight: 39 kg/m<sup>2</sup> (8.0 lb/ft<sup>2</sup>)</p>	<p data-bbox="597 1629 1010 1680"><b>System WSD240</b> <i>Finished one side.</i> 15.9mm (5/8") ProRoc Type X, 2 layers, corridor side.</p> <p data-bbox="597 1692 1279 1864">Install ProRoc J-track, I-stud and ProRoc Shaftliner panels in accordance with SHAFTWALL FRAMING DETAILS 1. Fasten base layer horizontally to corridor side with 25mm (1") screws spaced 300mm (12") o.c. starting 75mm (3") from the top of each I-stud. Fasten face layer vertically with 41mm (1 1/2") screws spaced 300mm (12") o.c. starting 150mm (6") from top of each stud. Screws are not required along top or bottom tracks. Joints must be offset in accordance with SHAFTWALL FRAMING DETAILS 2. Tape and finish corridor joints with ProRoc products.</p>	<p data-bbox="1328 1629 1464 1667">FIRE: ITS BPBC/WA 120-01</p> <p data-bbox="1328 1688 1455 1717">SOUND: WHI F6</p>

# SHAFTWALLS

## Non-load bearing

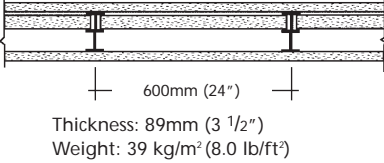
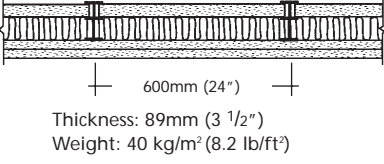
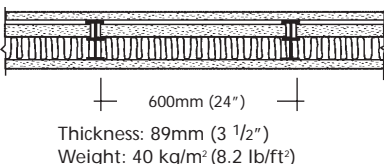
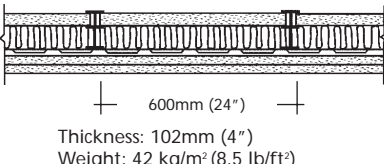
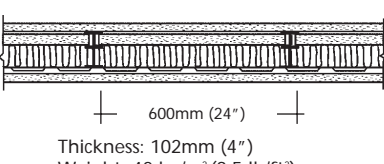
SOUND TRANSMISSION CLASS (STC)	CONSTRUCTION	DESCRIPTION	DESIGN NUMBER/TEST REPORTS
<b>FIRE RESISTANCE RATING: 2h (continued)</b>			
<b>41</b>	 <p>Thickness: 89mm (3 1/2") Weight: 39 kg/m<sup>2</sup> (8.0 lb/ft<sup>2</sup>)</p>	<p><b>System WSD241 Finished both sides.</b> 15.9mm (5/8") ProRoc Type X, 1 layer, corridor and shaft side.</p> <p>Install ProRoc J-track, I-stud and ProRoc Shaftliner panels in accordance with SHAFTWALL FRAMING DETAILS 1. Fasten boards horizontally to corridor side with 25mm (1") screws spaced 300mm (12") o.c. starting 75mm (3") from the top of each I-stud. Fasten boards vertically to the shaft side with (1") screws spaced 300mm (12") o.c. starting 75mm (3") from the top of each I-stud. Screws are not required along top or bottom tracks. Joints must be offset in accordance with SHAFTWALL FRAMING DETAILS 2. Tape and finish outer layer joints with ProRoc products.</p>	<p>FIRE: ITS BPBC/WA 120-02</p> <p>SOUND: WHI F4</p>
<b>48</b>	 <p>Thickness: 89mm (3 1/2") Weight: 40 kg/m<sup>2</sup> (8.2 lb/ft<sup>2</sup>)</p>	<p><b>System WSD248 Finished one side.</b> 15.9mm (5/8") ProRoc Type X, 2 layers, corridor side. Insulation within cavity.</p> <p>Install ProRoc J-track, I-stud and ProRoc Shaftliner panels in accordance with SHAFTWALL FRAMING DETAILS 1. Fasten base layer horizontally to corridor side with 25mm (1") screws spaced 300mm (12") o.c. starting 75mm (3") from the top of each I-stud. Fasten face layer vertically with 41mm (1 3/8") screws spaced 300mm (12") o.c. starting 150mm (6") from top of each stud. Screws are not required along top or bottom tracks. Joints must be offset in accordance with SHAFTWALL FRAMING DETAILS 2. Tape and finish corridor joints with ProRoc products.</p>	<p>FIRE: Based on WSD 240 (ITS BPBC/WA 120-01)</p> <p>SOUND: WHI F2</p>
<b>49</b>	 <p>Thickness: 89mm (3 1/2") Weight: 40 kg/m<sup>2</sup> (8.2 lb/ft<sup>2</sup>)</p>	<p><b>System WSD249 Finished both sides.</b> 15.9mm (5/8") ProRoc Type X, 1 layer, corridor and shaft side. Insulation within cavity.</p> <p>Install ProRoc J-track, I-stud and ProRoc Shaftliner panels in accordance with SHAFTWALL FRAMING DETAILS 1. Fasten boards horizontally to corridor side with 25mm (1") screws spaced 300mm (12") o.c. starting 75mm (3") from the top of each I-stud. Fasten boards vertically to the shaft side with (1") screws spaced 300mm (12") o.c. starting 75mm (3") from the top of each I-stud. Screws are not required along top or bottom tracks. Joints must be offset in accordance with SHAFTWALL FRAMING DETAILS 2. Tape and finish outer layer joints with ProRoc products.</p>	<p>FIRE: Based on WSD 241 (ITS BPBC/WA 120-02)</p> <p>SOUND: WHI F3</p>
<b>50</b>	 <p>Thickness: 102mm (4") Weight: 42 kg/m<sup>2</sup> (8.5 lb/ft<sup>2</sup>)</p>	<p><b>System WSD250 Finished one side.</b> 15.9mm (5/8") ProRoc Type X, 2 layers, corridor side. Insulation within cavity.</p> <p>Install ProRoc J-track, I-stud and ProRoc Shaftliner panels in accordance with SHAFTWALL FRAMING DETAILS 1. Install resilient channels on corridor side with tabs downwards, horizontally at 600mm (24") o.c. starting 50mm (2") from the top or bottom. Fasten resilient channels with 25mm (1") screws spaced 600mm (24") o.c. Fasten base layer horizontally to the resilient channels with 25mm (1") screws spaced 600mm (24") o.c. Fasten face layer vertically with 41mm (1 3/8") screws spaced 300mm (12") o.c. Screws are not required along top or bottom tracks. Joints must be offset in accordance with SHAFTWALL FRAMING DETAILS 2. Tape and finish corridor joints with ProRoc products.</p>	<p>FIRE: Based on WSD 240 (ITS BPBC/WA 120-01)</p> <p>SOUND: WHI F1</p>
<b>51</b>	 <p>Thickness: 102mm (4") Weight: 42 kg/m<sup>2</sup> (8.5 lb/ft<sup>2</sup>)</p>	<p><b>System WSD251 Finished both sides.</b> 15.9mm (5/8") ProRoc Type X, 1 layer, corridor and shaft side. Insulation within cavity.</p> <p>Install ProRoc J-track, I-stud and ProRoc Shaftliner panels in accordance with SHAFTWALL FRAMING DETAILS 1. Install resilient channels on corridor side with tabs downwards, horizontally at 600mm (24") o.c. starting 50mm (2") from the top or bottom. Fasten resilient channels with 25mm (1") screws spaced 600mm (24") o.c. Fasten boards horizontally to the resilient channels with 25mm (1") screws spaced 600mm (24") o.c. Fasten boards vertically to the shaft side with (1") screws spaced 300mm (12") o.c. starting 75mm (3") from the top of each I-stud. Screws are not required along top or bottom tracks. Joints must be offset in accordance with SHAFTWALL FRAMING DETAILS 2. Tape and finish outer layer joints with ProRoc products.</p>	<p>FIRE: Based on WSD 241 (ITS BPBC/WA 120-02)</p> <p>SOUND: Based on WSD250</p>

# SHAFTWALLS

## Non-load bearing

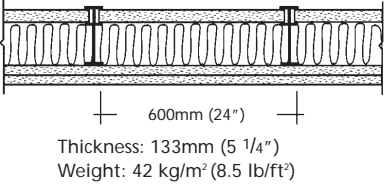
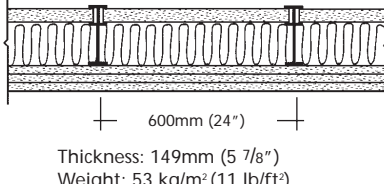
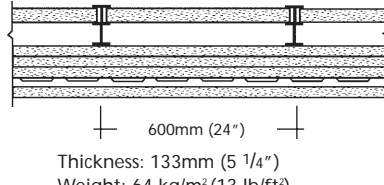
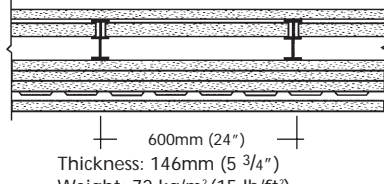
SOUND TRANSMISSION CLASS (STC)	CONSTRUCTION	DESCRIPTION	DESIGN NUMBER/TEST REPORTS
<b>FIRE RESISTANCE RATING: 2h (continued)</b>			
<b>54</b>	 <p>Thickness: 133mm (5 1/4") Weight: 42 kg/m<sup>2</sup> (8.5 lb/ft<sup>2</sup>)</p>	<p><b>System WSD254</b> <i>Finished one side.</i> 15.9mm (5/8") ProRoc Type X, 2 layers, corridor side. Glass fibre insulation 89mm (3 1/2") within cavity.</p> <p>Install 101mm (4") ProRoc J-track, I-stud and ProRoc Shaftliner panels in accordance with SHAFTWALL FRAMING DETAILS 1. Fasten base layer horizontally to corridor side with 25mm (1") screws spaced 300mm (12") o.c. starting 75mm (3") from the top of each I-stud. Fasten face layer vertically with 41mm (1 1/2") screws spaced 300mm (12") o.c. starting 150mm (6") from top of each stud. Screws are not required along top or bottom tracks. Joints must be offset in accordance with SHAFTWALL FRAMING DETAILS 2. Tape and finish corridor joints with ProRoc products.</p>	<p>FIRE: Based on WSD 240 (ITS BPBC/WA 120-01)</p> <p>SOUND: NRC TL-94-037</p>
<b>56</b>	 <p>Thickness: 149mm (5 7/8") Weight: 53 kg/m<sup>2</sup> (11 lb/ft<sup>2</sup>)</p>	<p><b>System WSD256</b> <i>Finished one side.</i> 15.9mm (5/8") ProRoc Type X, 3 layers, corridor side. Glass fibre insulation 89mm (3 1/2") within cavity.</p> <p>Install 101mm (4") ProRoc J-track, I-stud and ProRoc Shaftliner panels in accordance with SHAFTWALL FRAMING DETAILS 1. Fasten base layer horizontally to corridor side with 25mm (1") screws spaced 300mm (12") o.c. starting 75mm (3") from the top of each I-stud. Fasten second layer vertically with 41mm (1 1/2") screws spaced 300mm (12") o.c. starting 150mm (6") from top of each stud. Fasten third layer vertically or horizontally with 57mm (2 1/4") screws spaced 300mm (12") o.c. Screws are not required along top or bottom tracks. Joints must be offset in accordance with SHAFTWALL FRAMING DETAILS 2. Tape and finish corridor joints with ProRoc products.</p>	<p>FIRE: Based on WSD 240 (ITS BPBC/WA 120-01)</p> <p>SOUND: NRC TL-94-038</p>
<b>FIRE RESISTANCE RATING: 3h</b>			
<b>42</b>	 <p>Thickness: 133mm (5 1/4") Weight: 64 kg/m<sup>2</sup> (13 lb/ft<sup>2</sup>)</p>	<p><b>System WSD342</b> <i>Finished one side.</i> 15.9mm (5/8") ProRoc Type X, 4 layers, corridor side.</p> <p>Install ProRoc J-track, I-stud and ProRoc Shaftliner panels in accordance with SHAFTWALL FRAMING DETAILS 1. Fasten base layer horizontally to corridor side with 25mm (1") screws spaced 300mm (12") o.c. starting 75mm (3") from the top of each I-stud. Fasten second layer vertically with 41mm (1 1/2") screws spaced 1067mm (42") o.c. starting 300mm (12") from top of each stud. Fasten third layer vertically with 57mm (2 1/4") screws spaced 600mm (24") o.c. starting 355mm (14") from top of each stud. Install resilient channels with tabs downwards, horizontally at 600mm (24") o.c. starting 50mm (2") from the top or bottom. Fasten resilient channels with 57mm (2 1/4") screws spaced 600mm (24") o.c. Fasten fourth layer vertically to resilient channels with 25mm (1") screws spaced 300mm (12") o.c. Screws are not required along top or bottom tracks. Joints must be offset in accordance with SHAFTWALL FRAMING DETAILS 2. Tape and finish corridor joints with ProRoc products.</p>	<p>FIRE: ITS BPBC/WA 180-01</p> <p>SOUND: WHI F12</p>
<b>47</b>	 <p>Thickness: 146mm (5 3/4") Weight: 72 kg/m<sup>2</sup> (15 lb/ft<sup>2</sup>)</p>	<p><b>System WSD347</b> <i>Finished both sides.</i> 15.9mm (5/8") ProRoc Type X, 4 layers, corridor side.</p> <p>Install ProRoc J-track, I-stud and ProRoc Shaftliner panels in accordance with SHAFTWALL FRAMING DETAILS 1. Fasten base layer boards horizontally to corridor side with 25mm (1") screws spaced 300mm (12") o.c. starting 75mm (3") from the top of each I-stud. Fasten second layer vertically with 41mm (1 1/2") screws spaced 1067mm (42") o.c. starting 300mm (12") from top of each stud. Fasten third layer vertically with 57mm (2 1/4") screws spaced 600mm (24") o.c. starting 355mm (14") from top of each stud. Install resilient channels with tabs downwards, horizontally at 600mm (24") o.c. starting 50mm (2") from the top or bottom. Fasten resilient channels with 57mm (2 1/4") screws spaced 600mm (24") o.c. Fasten fourth layer vertically with 25mm (1") screws spaced 300mm (12") o.c. Fasten 12.7mm (1/2") ProRoc Regular boards vertically on the shaft side with 25mm (1") screws spaced 300mm (12") o.c. starting 75mm (3") from the top of each I-stud. Screws are not required along top or bottom tracks. Joints must be offset in accordance with SHAFTWALL FRAMING DETAILS 2. Tape and finish corridor joints with ProRoc products.</p>	<p>FIRE: Based on WSD 342 (ITS BPBC/WA 180-01)</p> <p>SOUND: WHI F11</p>

# SHAFTWALLS

## Non-load bearing

SOUND TRANSMISSION CLASS (STC)	CONSTRUCTION	DESCRIPTION	DESIGN NUMBER/TEST REPORTS
--------------------------------	--------------	-------------	----------------------------

**FIRE RESISTANCE RATING: 3h (continued)**

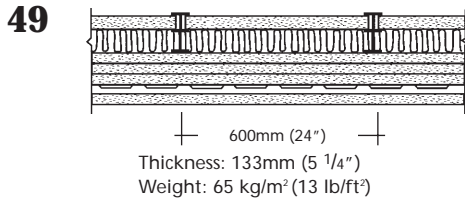

**System WSD349 Finished one side**  
15.9mm (5/8") ProRoc Type X, 4 layers, corridor side. Insulation within cavity.

Install ProRoc J-track, I-stud and ProRoc Shaftliner panels in accordance with SHAFTWALL FRAMING DETAILS 1. Fasten base layer horizontally to corridor side with 25mm (1") screws spaced 300mm (12") o.c. starting 75mm (3") from the top of each I-stud. Fasten second layer vertically with 41mm (1 5/8") screws spaced 1067mm (42") o.c. starting 300mm (12") from top of each stud. Fasten third layer vertically with 57mm (2 1/4") screws spaced 600mm (24") o.c. starting 355mm (14") from top of each stud. Install resilient channels with tabs downwards, horizontally at 600mm (24") o.c. starting 50mm (2") from the top or bottom. Fasten resilient channels with 57mm (2 1/4") screws spaced 600mm (24") o.c. Fasten fourth layer vertically to resilient channels with 25mm (1") screws spaced 300mm (12") o.c. Screws are not required along top or bottom tracks. Joints must be offset in accordance with SHAFTWALL FRAMING DETAILS 2. Tape and finish corridor joints with ProRoc products.

FIRE: Based on WSD 342 (ITS BPBC/WA 180-01)  
SOUND: WHI F9

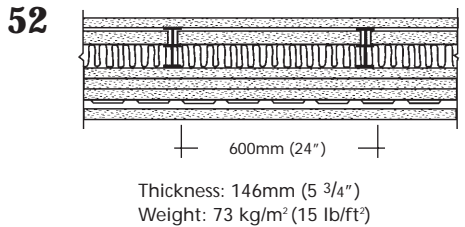

**System WSD352 Finished both sides**  
15.9mm (5/8") ProRoc Type X, 4 layers, corridor side. Insulation within cavity.

Install ProRoc J-track, I-stud and ProRoc Shaftliner panels in accordance with SHAFTWALL FRAMING DETAILS 1. Fasten base layer horizontally to corridor side with 25mm (1") screws spaced 300mm (12") o.c. starting 75mm (3") from the top of each I-stud. Fasten second layer vertically with 41mm (1 5/8") screws spaced 1067mm (42") o.c. starting 300mm (12") from top of each stud. Fasten third layer vertically with 57mm (2 1/4") screws spaced 600mm (24") o.c. starting 355mm (14") from top of each stud. Install resilient channels with tabs downwards, horizontally at 600mm (24") o.c. starting 50mm (2") from the top or bottom. Fasten resilient channels with 57mm (2 1/4") screws spaced 600mm (24") o.c. Fasten fourth layer vertically to the resilient channels with 25mm (1") screws spaced 300mm (12") o.c. Fasten 12.7mm (1/2") ProRoc Regular boards vertically on the shaft side with 25mm (1") screws spaced 300mm (12") o.c. starting 75mm (3") from the top of each I-stud. Screws are not required along top or bottom tracks. Joints must be offset in accordance with SHAFTWALL FRAMING DETAILS 2. Tape and finish corridor joints with ProRoc products.

FIRE: Based on WSD 342 (ITS BPBC/WA 180-01)  
SOUND: WHI F10

# HORIZONTAL SHAFT SYSTEM

Non-load bearing

# SYSTEM WSD2H

**Horizontal Applications**  
(e.g. CORRIDORS, DUCT ENCLOSURES, ETC.)

## Construction

**FIRE-TESTED  
2 HOUR  
HORIZONTAL  
ASSEMBLY**

**FIRE-TEST:  
WHI-495-PSH-189 & 190  
(tested from both sides)**

**OBMEC  
AUTHORIZATION  
NUMBER: 92-6-162**

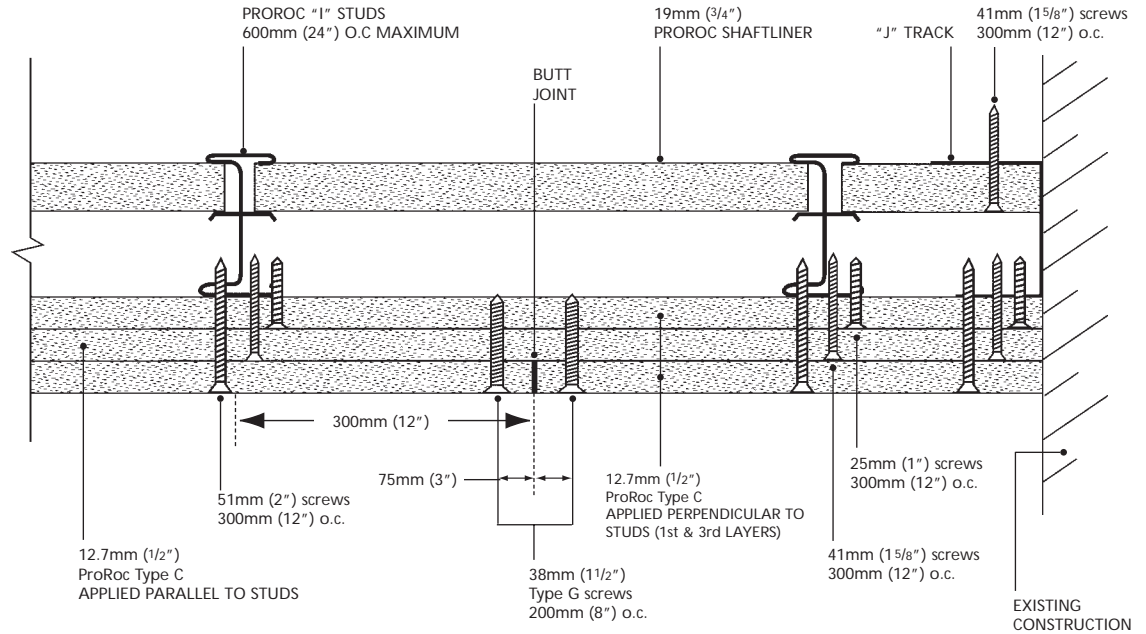

I Stud/J Track Depth	I Stud/J Track Thickness	Allowable Stud Span*	
		mm	ft
57mm (2 1/4")	25 ga	2010	6'7"
101mm (4")	20 ga	2240	7'4"
152mm (6")	20 ga	3320	10'6"
		3710	12'2"

\* Spans of horizontal membranes (ceilings over corridors or stairways) should not exceed those shown above.

## Horizontal Duct Enclosure

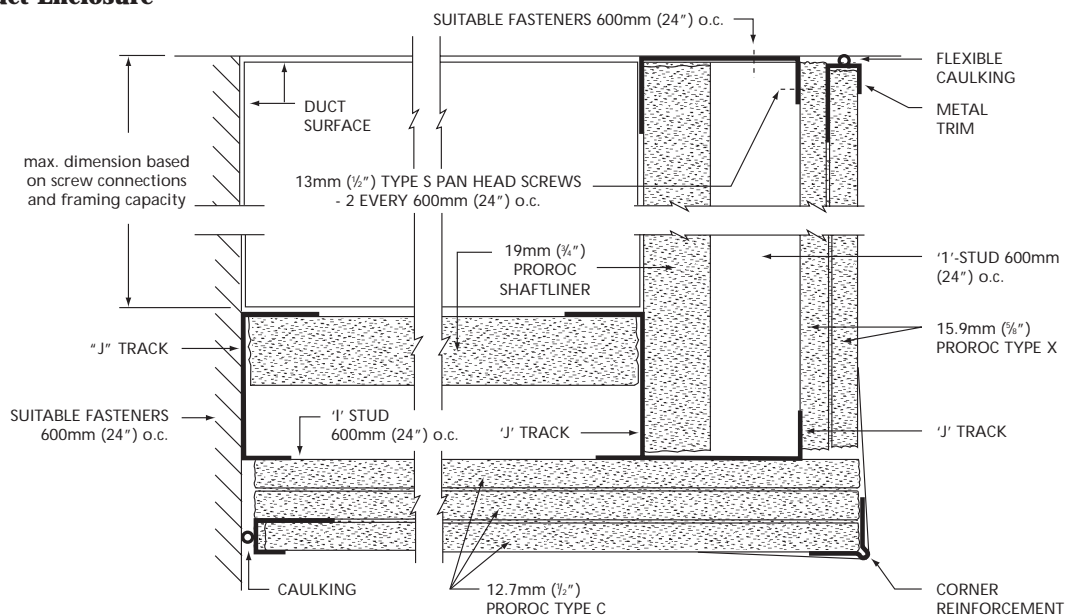

# SHAFTWALLS

## Non-load bearing

# ADDITIONAL DETAILS

### 1 hr. rating - finished one side

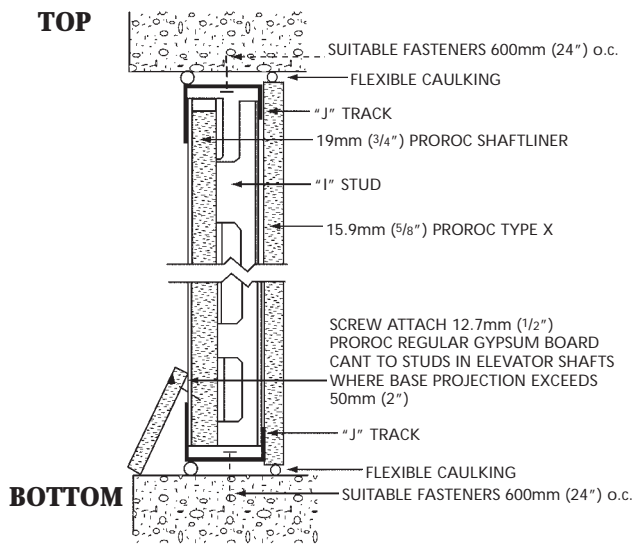
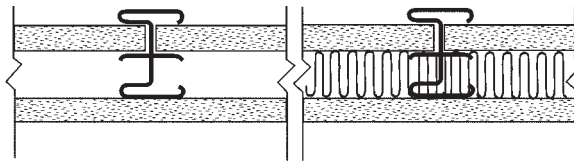

#### WALL INTERSECTION ON SHAFTLINER SIDE

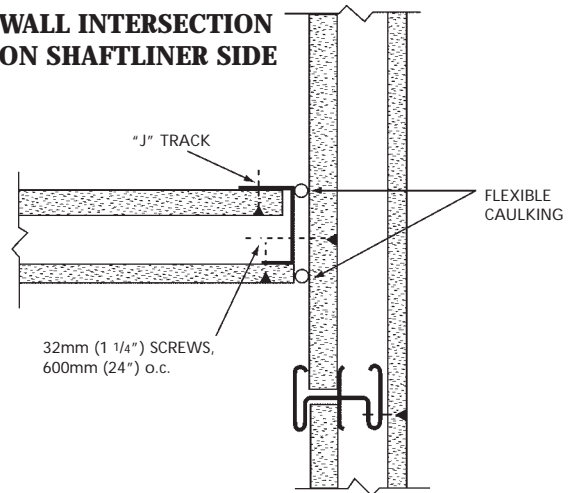

#### WALL INTERSECTION ON FINISHED SIDE

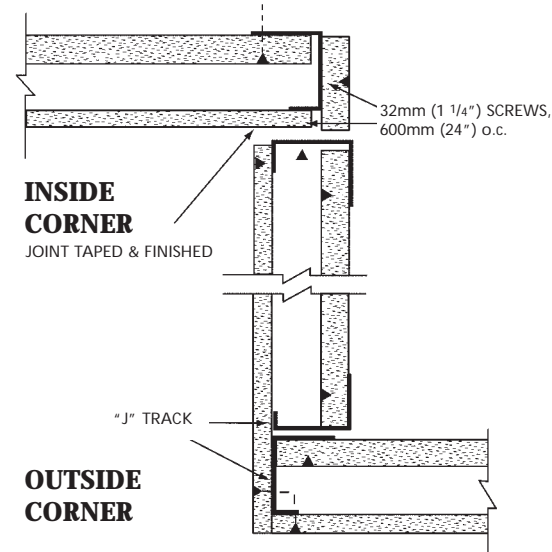
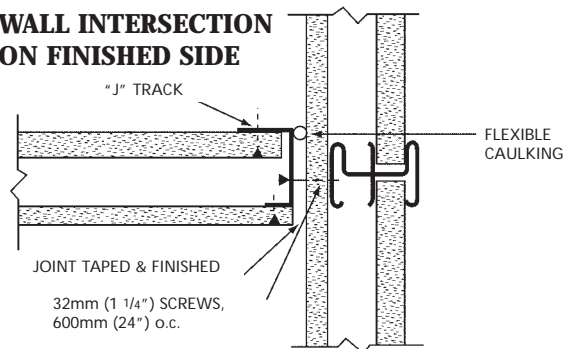

#### ABUTMENT TO MASONRY

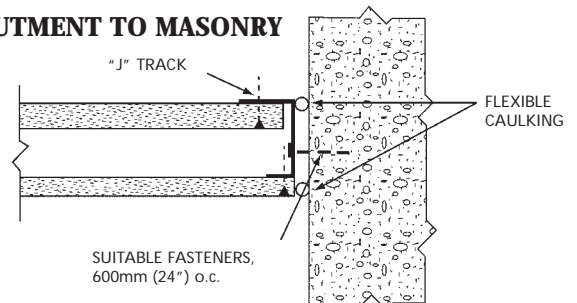

# SHAFTWALLS

## Non-load bearing

# ADDITIONAL DETAILS

### 2 hr. rating - finished one side

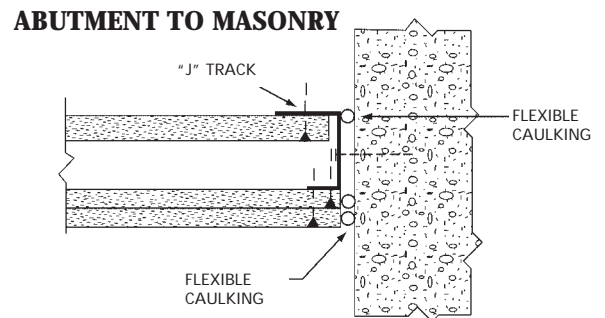
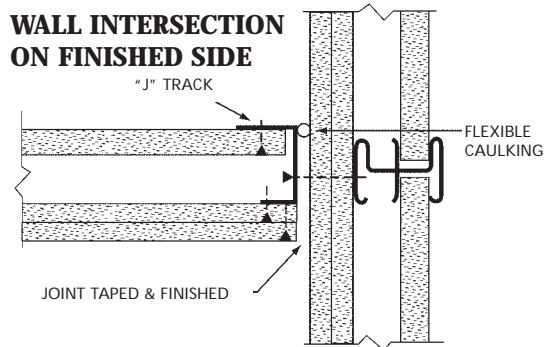
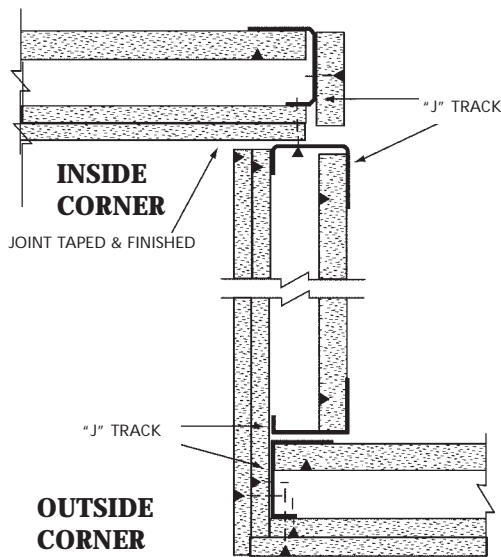
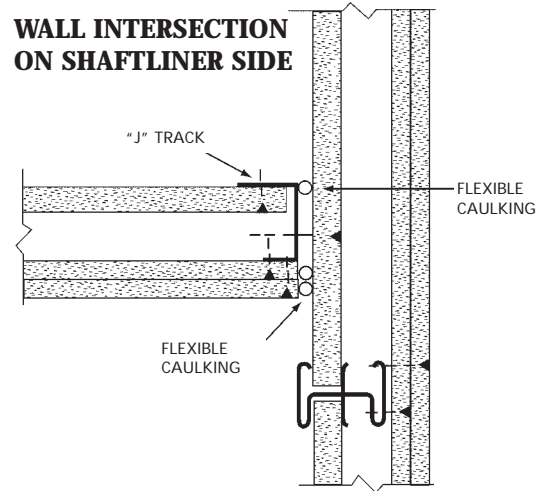
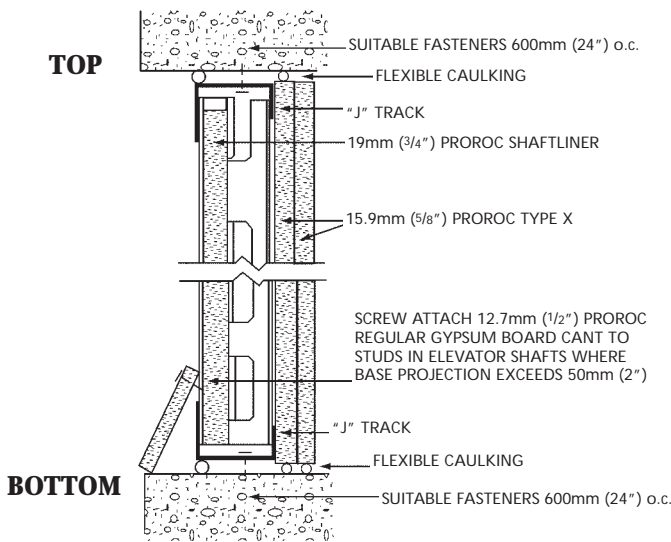
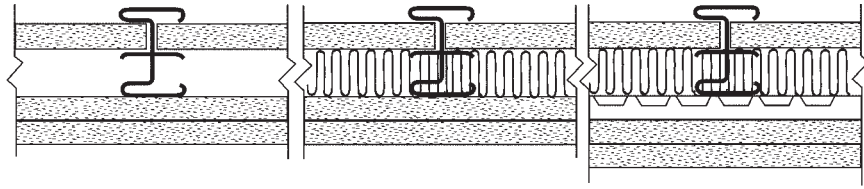

# SHAFTWALLS

## Non-load bearing

# ADDITIONAL DETAILS

2 hr. rating - finished both sides

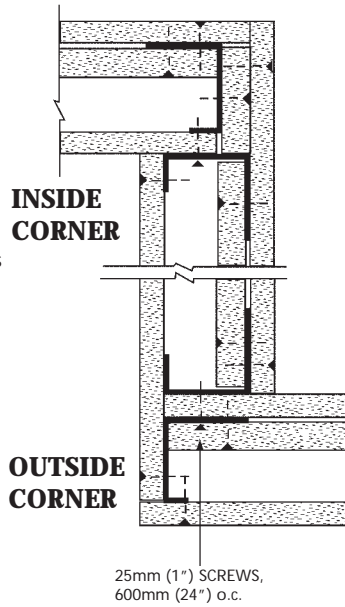
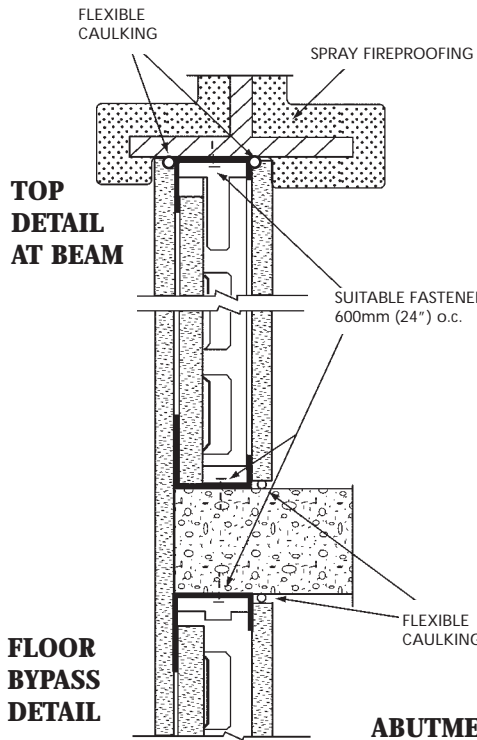
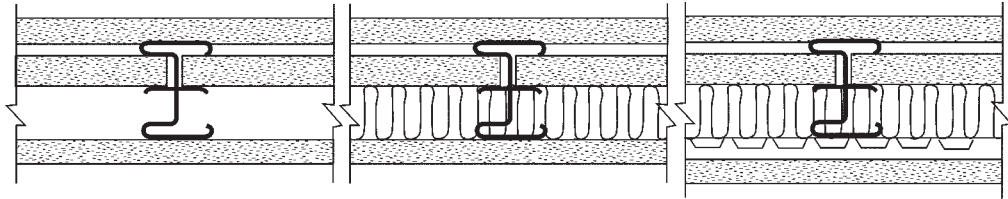

**WALL INTERSECTION ON SHAFTLINER SIDE**

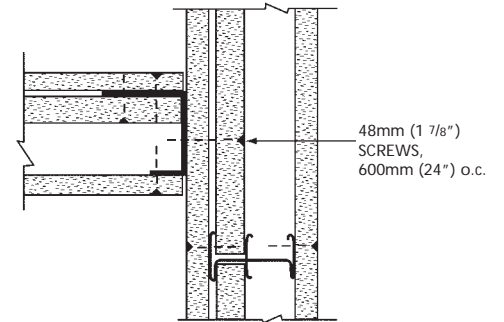

**WALL INTERSECTION ON CAVITY SIDE**

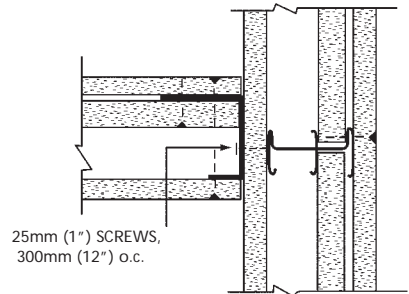

**ABUTMENT TO MASONRY**

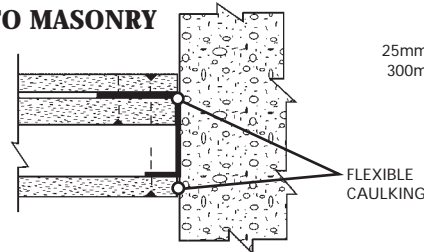

# SHAFTWALLS

## Non-load bearing

# ADDITIONAL DETAILS

### 3 hr. rating - finished one side

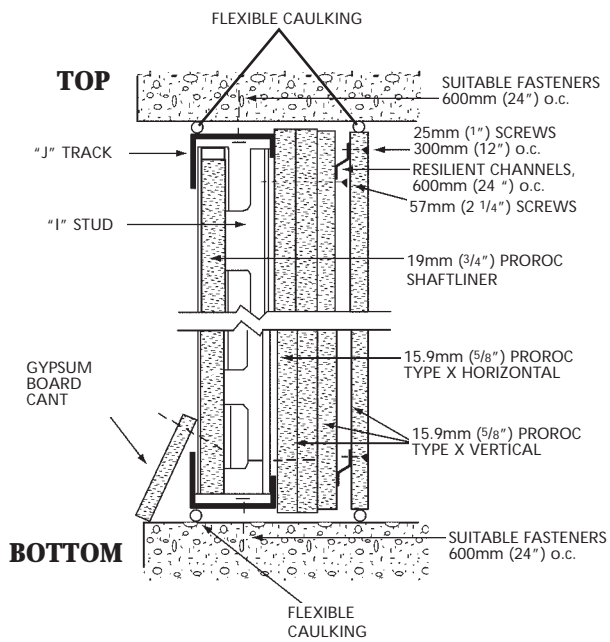
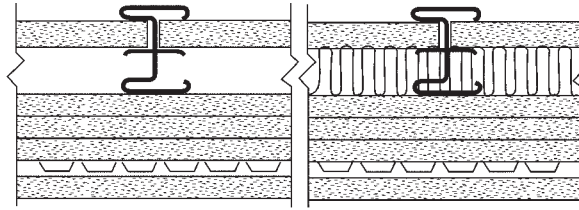

### WALL INTERSECTION ON SHAFTLINER SIDE

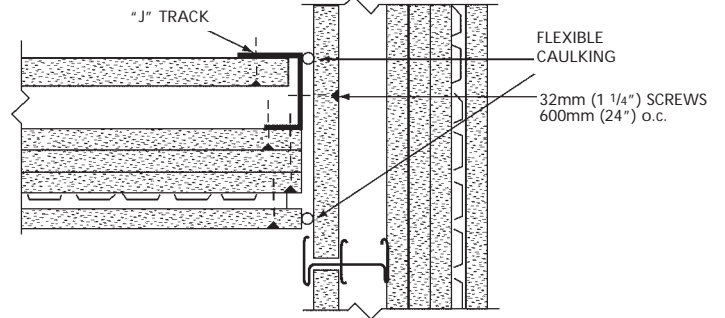

### WALL INTERSECTION ON FINISHED SIDE

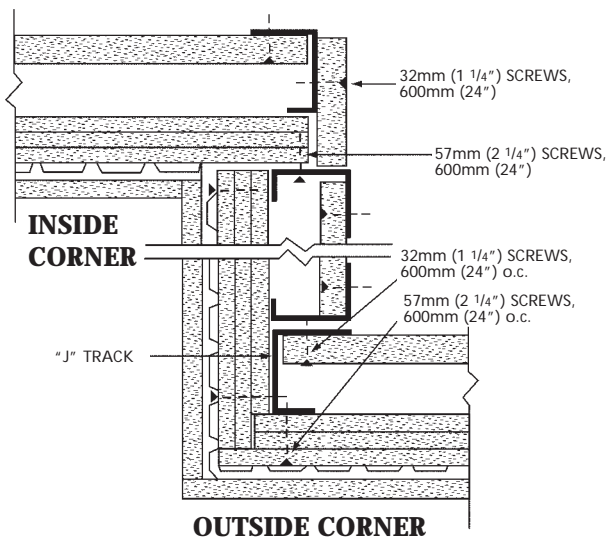
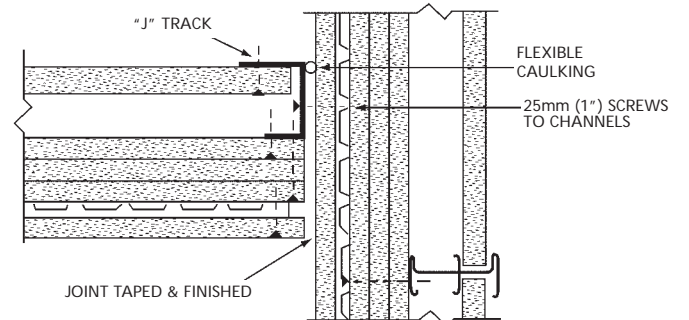

### ABUTMENT TO MASONRY

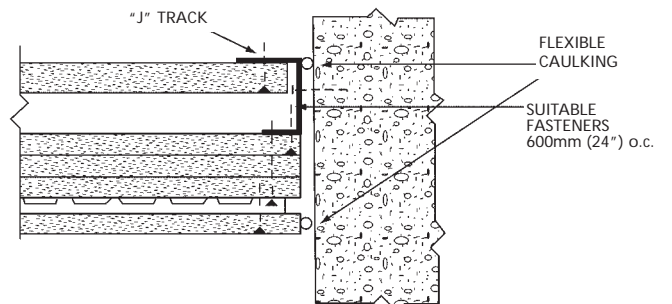

# SHAFTWALLS

## Non-load bearing

# ADDITIONAL DETAILS

### 3 hr. rating - finished both sides

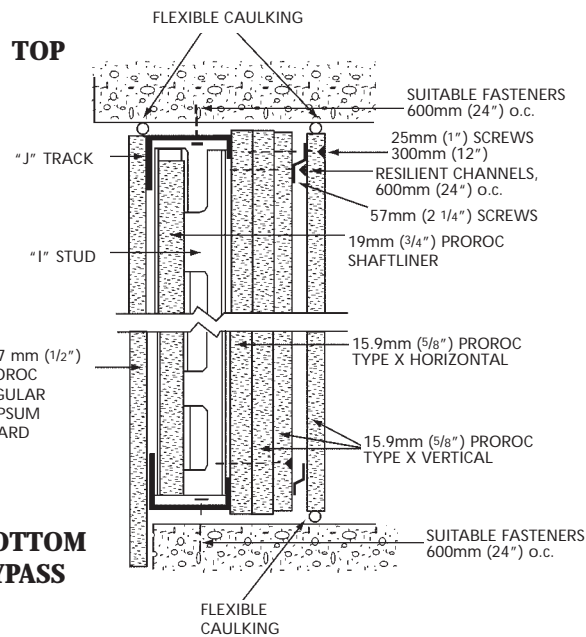
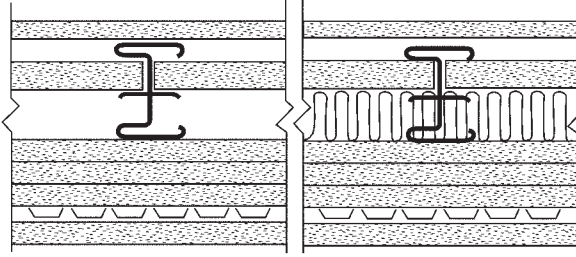

### WALL INTERSECTION ON SHAFTLINER SIDE

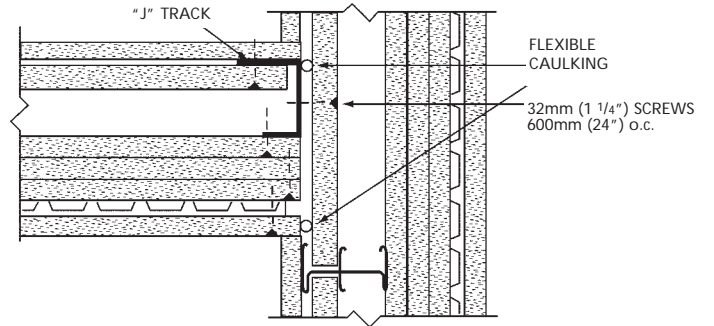

### WALL INTERSECTION ON CAVITY SIDE

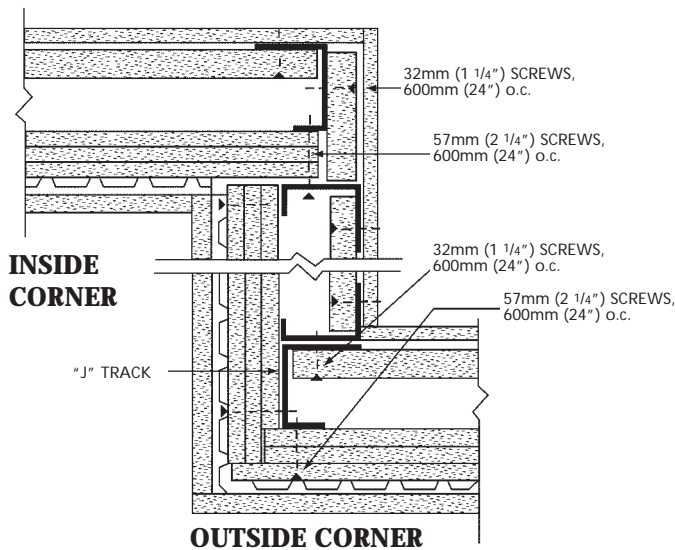
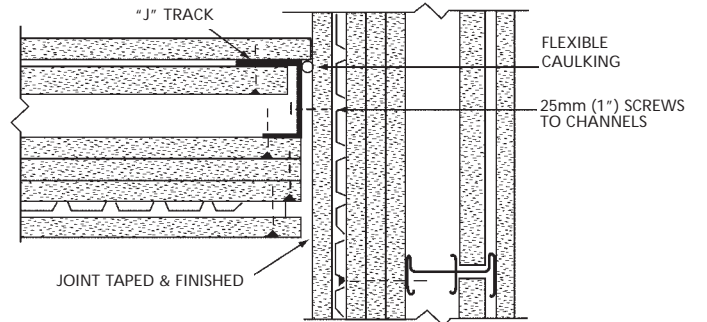

### ABUTMENT TO MASONRY

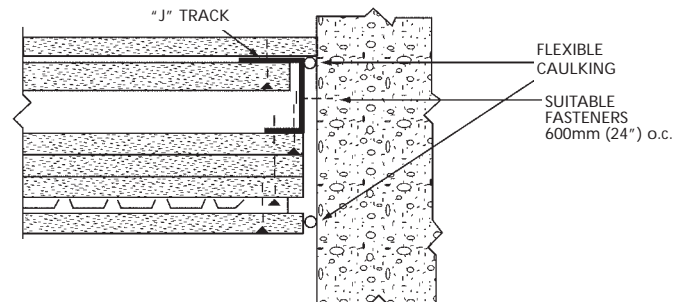

# SHAFTWALLS

## Non-load bearing

# ACCESSORY DETAILS

Illustrated with  
2 hr. rated assembly

### OUTLET BOX

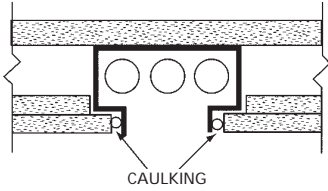

### CONTROL JOINT

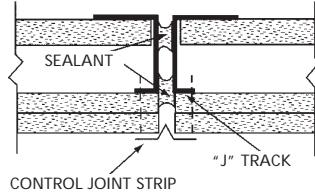

### SERVICE PENETRATION DETAIL

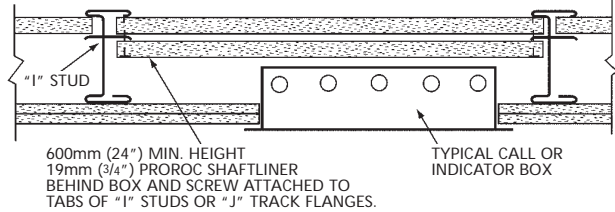

### STEEL BEAM

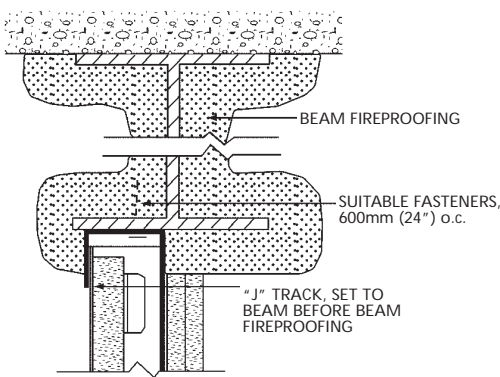

### STEEL BEAM OFFSET

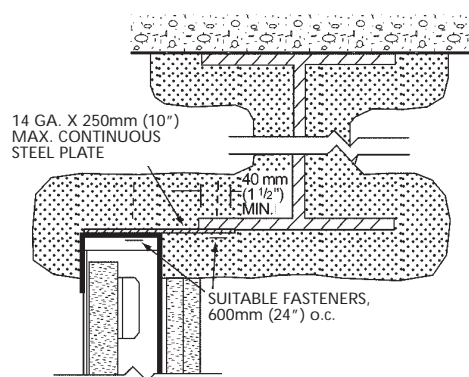

NOTE:  
CAVITY DEPTH  
REQUIREMENTS MAY  
VARY ACCORDING TO  
SERVICES BEING  
INSTALLED.

### CORNER COLUMN BYPASS

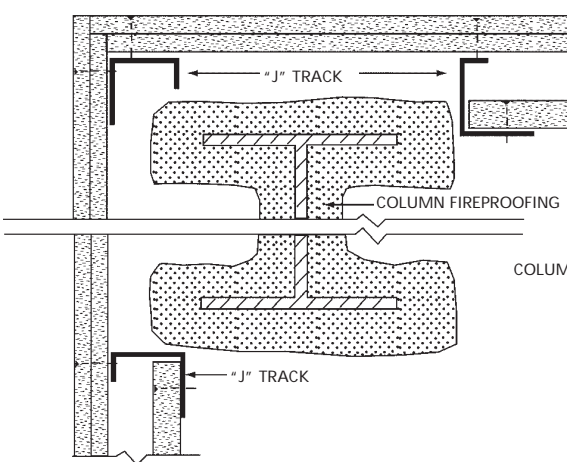

### BYPASS OF LARGE COLUMNS

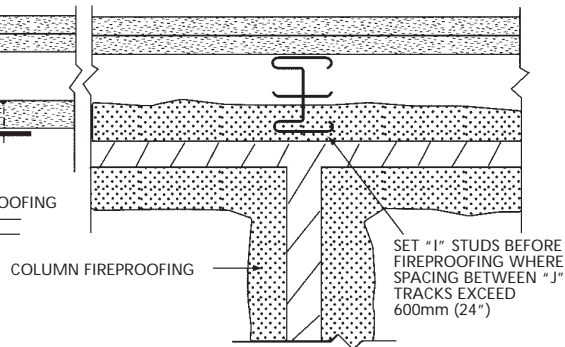

### HAND RAIL ATTACHMENTS

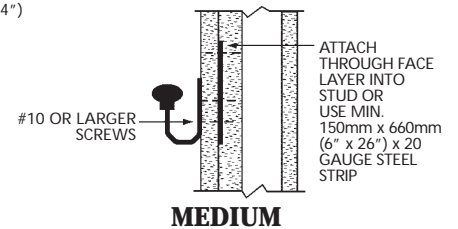
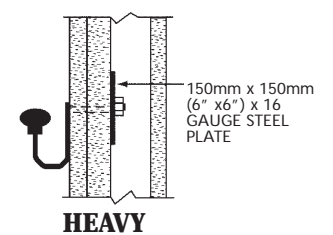

### end of wall (alternate detail)

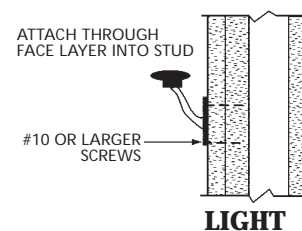
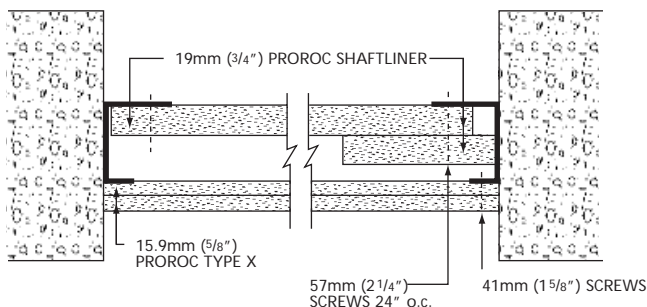

# SHAFTWALLS

## Non-load bearing

# ACCESSORY DETAILS

Illustrated with  
2 hr. rated assembly

**DOOR OPENING ROOM SIDE**

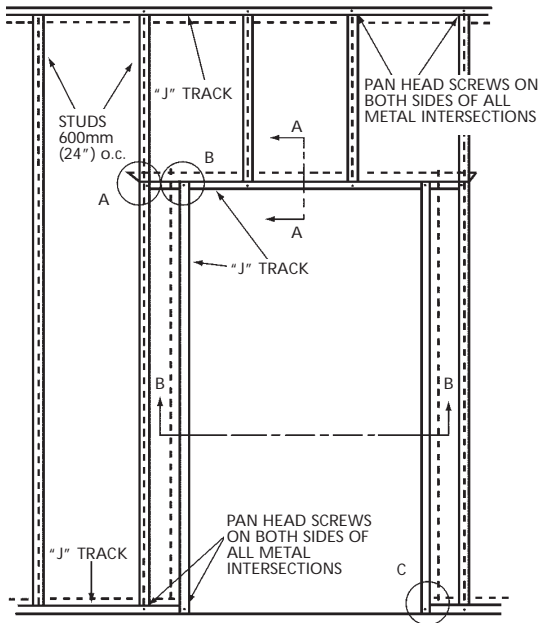

**HEADER DETAIL A-A**

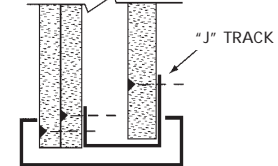

**CROSS SECTION B-B**

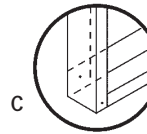
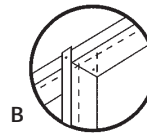
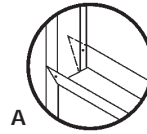
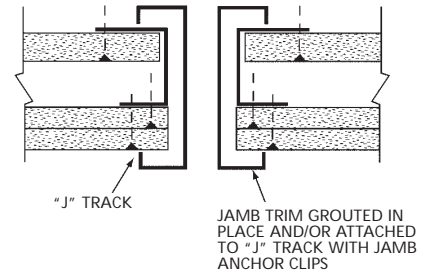

**DUCT OPENING ROOM SIDE**

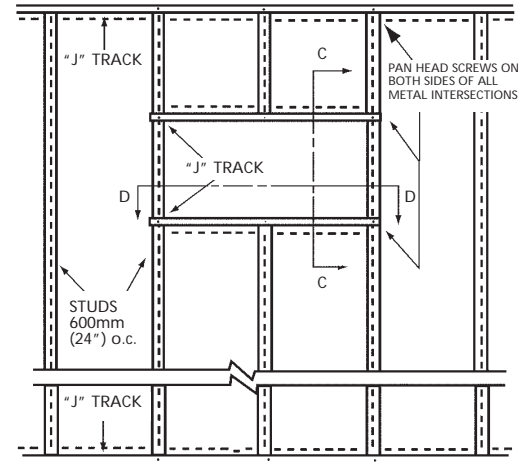

**DUCT DETAIL C-C**

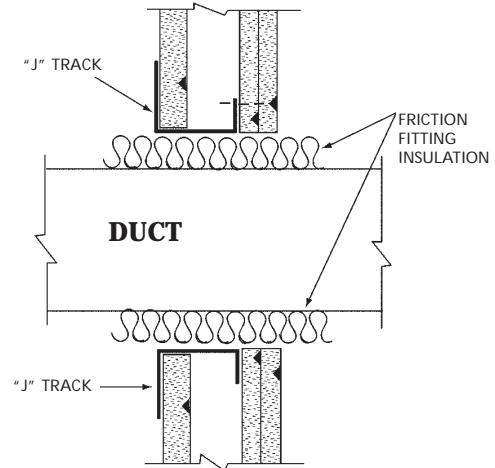

**DUCT DETAIL D-D**

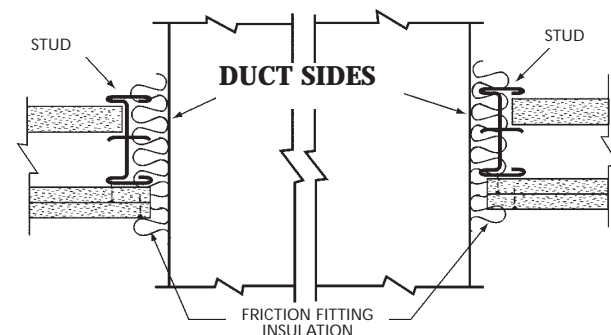

NOTE: Clearance openings and attachment details should be as per fire damper manufacturer's installation requirements.

# EXTERIOR WALLS

## Load bearing

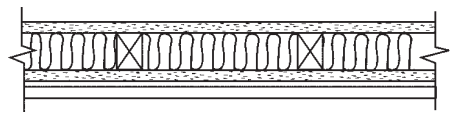
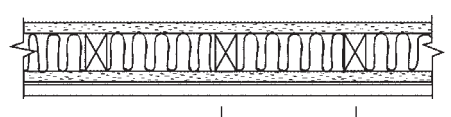
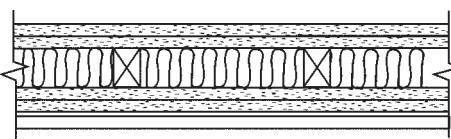
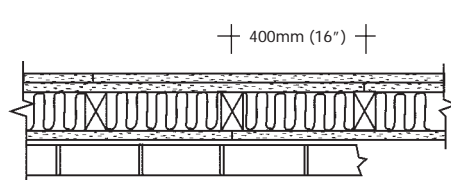
SOUND TRANSMISSION CLASS (STC)	CONSTRUCTION	DESCRIPTION	DESIGN NUMBER/TEST REPORTS
<b>FIRE RESISTANCE RATING: 1h</b>			
<b>36</b>	 <p style="text-align: center;">+ 400mm (16") +</p> <p>Thickness: 121mm (4 3/4") (plus cladding) Weight: 31 kg/m<sup>2</sup> (6.3 lb/ft<sup>2</sup>) (plus cladding)</p>	<p><b>WXE136</b></p> <p>Fasten 1 layer of 15.9mm (5/8") ProRoc Type X vertically to interior side of 38mm x 89mm (2 x 4) wood studs. Fasten 1 layer of 15.9mm (5/8") ProRoc Treated Core Sheathing Type X or GlasRoc Sheathing Type X vertically to exterior side. Glass fibre or mineral wool insulation 89mm (3 1/2") within cavity. 51mm (2") nails spaced 175mm (7") o.c. Joints must be offset. Tape and finish interior joints with ProRoc products. Exterior cladding system applied.</p>	<p>FIRE: ULC W301</p> <p>SOUND: NBCC (1995) Table A-9.10.3.1.A Wall W1a</p>
<b>37</b>	 <p style="text-align: center;">+ 400mm (16") +</p> <p>Thickness: 117mm (4 5/8") (plus cladding) Weight: 33 kg/m<sup>2</sup> (6.7 lb/ft<sup>2</sup>) (plus cladding)</p>	<p><b>WXE137</b></p> <p>Fasten 1 layer of 15.9mm (5/8") ProRoc Type X vertically or horizontally to interior side of 38mm x 89mm (2 x 4) wood studs with 38mm (1 1/2") drywall nails spaced 200mm (8") o.c. or 41mm (1 5/8") screws spaced 300mm (12") o.c. Fasten 1 layer of 12.7mm (1/2") ProRoc Treated Core Sheathing or GlasRoc Sheathing horizontally to exterior side with 44mm (1 3/4") roofing nails spaced 150mm (6") o.c. Mineral wool insulation 89mm (3 1/2") within cavity. Joints must be offset. Tape and finish interior joints with ProRoc products. Exterior cladding system applied.</p>	<p>FIRE: NBCC (1995) Table A-9.10.3.1.A Wall EW1a</p> <p>SOUND: Estimated</p>
<b>FIRE RESISTANCE RATING: 2h</b>			
<b>38</b>	 <p style="text-align: center;">+ 400mm (16") +</p> <p>Thickness: 152mm (6") (plus cladding) Weight: 54 kg/m<sup>2</sup> (11 lb/ft<sup>2</sup>) (plus cladding)</p>	<p><b>WXE238</b></p> <p>Fasten base layer of 15.9mm (5/8") ProRoc Type X vertically or horizontally to interior side of 38mm x 89mm (2 x 4) wood studs with 48mm (1 5/8") nails spaced 150mm (6") o.c. Fasten face layer of 15.9mm (5/8") ProRoc Type X vertically or horizontally with 60mm (2 3/8") nails spaced 200mm (8") o.c. Fasten base layer of 15.9mm (5/8") ProRoc Treated Core Sheathing Type X or GlasRoc Sheathing Type X vertically or horizontally to exterior side 48mm (1 5/8") nails spaced 150mm (6") o.c. Fasten face layer of 15.9mm (5/8") ProRoc Sheathing Type X or GlasRoc Sheathing Type X vertically or horizontally with 60mm (2 3/8") nails spaced 200mm (8") o.c. Glass fibre or mineral wool insulation 89mm (3 1/2") within cavity. Joints must be offset. Tape and finish interior joints with ProRoc products. Exterior cladding system applied.</p>	<p>FIRE: ULI U301</p> <p>SOUND: NBCC (1995) Table A-9.10.3.1.A Wall W2a</p>
<b>42</b>	 <p style="text-align: center;">+ 400mm (16") +</p> <p>Thickness: 255mm (10")</p>	<p><b>WXE242</b></p> <p>Fasten base layer of 15.9mm (5/8") ProRoc Type X vertically or horizontally to interior side of 38mm x 89mm (2 x 4) wood studs with 51mm (2") cement-coated nails spaced 200mm (8") o.c. Fasten face layer of 15.9mm (5/8") ProRoc Type X vertically or horizontally with 63mm (2 1/2") cement-coated nails spaced 200mm (8") o.c. Fasten 1 layer of 12.7mm (1/2") ProRoc Treated Core Sheathing or GlasRoc Sheathing horizontally to exterior side with 44mm (1 3/4") roofing nails spaced 150mm (6") o.c. Glass fibre or mineral wool insulation 89mm (3 1/2") within cavity. Joints must be offset. Tape and finish interior joints with ProRoc products. Exterior brick veneer system applied.</p>	<p>FIRE: ULC U302</p> <p>SOUND: Estimated</p>

\* Note: Any wall as listed in "Wood Stud Partitions" may also be used as an exterior wall, provided it is covered with a sheathing membrane and exterior cladding.

# STEEL JOIST FLOORS & CEILINGS

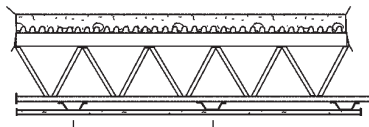
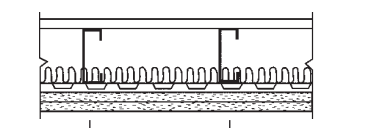
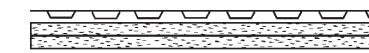
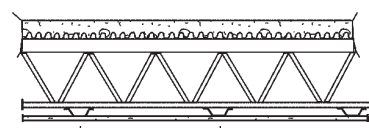
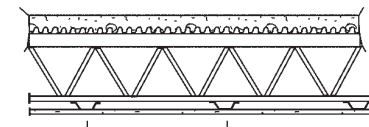
SOUND TRANSMISSION CLASS (STC)	CONSTRUCTION	DESCRIPTION	DESIGN NUMBER/ TEST REPORTS
<b>FIRE RESISTANCE RATING: 1h</b>			
<b>53</b>	 <p style="text-align: center;">+ 600mm (24") +</p> <p style="text-align: center;">Thickness: 395mm (15 1/2") Weight: 156 kg/m<sup>2</sup> (32 lb/ft<sup>2</sup>)</p>	<p><b>System WFS1B</b> 51mm (2"), 19 MPa (2800 psi) concrete floor. 15.9mm (5/8") ProRoc Type X, 1 layer on steel furring channels.</p> <p>Fasten boards perpendicular to furring channels with 25mm (1") screws spaced 300mm (12") o.c. Locate screws 10mm (3/8") minimum from edges and ends of board. Joints must be offset. Tape and finish joints with ProRoc products.</p>	<p>FIRE: ULC I509 SOUND: Estimated</p>
<b>54</b>	 <p style="text-align: center;">+ 600mm (24") +</p> <p style="text-align: center;">Thickness: 257mm (10 1/8") Weight: 68 kg/m<sup>2</sup> (14 lb/ft<sup>2</sup>)</p>	<p><b>System WFS154</b> 12.7mm (1/2") ProRoc Type C or 15.9mm (5/8") ProRoc Type X, 2 layers. Cold formed steel joists, resilient channels and 150mm(6") glass fibre or mineral wool insulation. Subfloor-plywood, OSB or waferboard.</p> <p>Fasten base layer perpendicular to resilient channels with 32mm (1 1/4") screws spaced 300mm (12") o.c. Fasten face layer perpendicular to resilient channels with 41mm (1 3/8") screws spaced 300mm (12") o.c. Locate face layer end joints at double resilient channels. Locate screws minimum of 38mm (1 1/2") from edges of board. Joints must be offset. Tape and finish joints with ProRoc products.</p>	<p>FIRE: NRC 98-764/ NBCC Table A-9.10.3.1B Floor F45 SOUND: NRC-IR-766</p>
<b>N/A</b>	<p>Gypsum boards applied to underside of steel supports maximum spacing 600mm (24") o.c.</p>  <p style="text-align: center;">Thickness: Varies Weight: 22 kg/m<sup>2</sup> (4.6 lb/ft<sup>2</sup>) plus framing</p>	<p><b>System WFS1XX</b> Fire rating provided by membrane only. 15.9mm (5/8") ProRoc Type X, 2 layers, steel structural member, maximum spacing 600mm (24") o.c.</p> <p>Fasten base layer perpendicular to supports with 25mm (1") screws spaced 300mm (12") o.c. Fasten face layer perpendicular to supports with 41mm (1 3/8") screws spaced 300mm (12") o.c. Joints must be offset. Tape and finish joints with ProRoc products.</p>	<p>FIRE: NBCC (1995) Appendix D Table D.2.3.12 SOUND: -</p>
<b>FIRE RESISTANCE RATING: 1-1/2 h</b>			
<b>53</b>	 <p style="text-align: center;">+ 600mm (24") +</p> <p style="text-align: center;">Thickness: 390mm (15 3/8") Weight: 166 kg/m<sup>2</sup> (34 lb/ft<sup>2</sup>)</p>	<p><b>System WFS1C</b> 51mm (2"), 21 MPa (3100 psi) concrete floor. 12.7mm (1/2") ProRoc Type C, 1 layer on steel furring channels.</p> <p>Fasten boards perpendicular to furring channels with 25mm (1") screws spaced 200mm (8") o.c. along end joints and 300mm (12") o.c. in the field. Locate screws 15mm (5/8") minimum from edges and ends of board. Joints must be offset. Tape and finish joints with ProRoc products.</p>	<p>FIRE: ULC I510 SOUND: Estimated</p>
<b>FIRE RESISTANCE RATING: 2h</b>			
<b>54</b>	 <p style="text-align: center;">+ 600mm (24") +</p> <p style="text-align: center;">Thickness: 355mm (14") Weight: 190 kg/m<sup>2</sup> (39 lb/ft<sup>2</sup>)</p>	<p><b>System WFS2B</b> 64mm (2 1/2"), 28 MPa (4000 psi) concrete floor. 12.7mm (1/2") ProRoc Type C, 1 layer on steel furring channels.</p> <p>Fasten boards perpendicular to furring channels with 25mm (1") screws spaced 200mm (8") o.c. along end joints and 300mm (12") o.c. in the field. Locate screws 38mm (1 1/2") minimum from edges and ends of board. Joints must be offset. Tape and finish joints with ProRoc products.</p>	<p>FIRE: ULC I511 SOUND: Estimated</p>

# STEEL JOIST FLOORS & CEILINGS

SOUND TRANSMISSION CLASS (STC)	CONSTRUCTION	DESCRIPTION	DESIGN NUMBER/TEST REPORTS
--------------------------------	--------------	-------------	----------------------------

## FIRE RESISTANCE RATING: 2 h (continued)

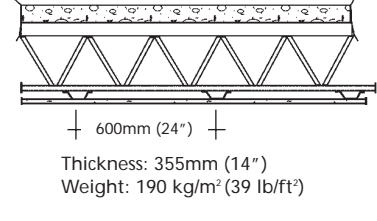
<p><b>54</b></p>	 <p style="text-align: center;">+ 600mm (24") +</p> <p>Thickness: 355mm (14") Weight: 190 kg/m<sup>2</sup> (39 lb/ft<sup>2</sup>)</p>	<p><b>System WFS2E</b> 64mm (2½"), 24 MPa (3500 psi) concrete floor. 12.7mm (½") ProRoc Type C, 1 layer on steel furring channels.</p> <p>Fasten boards perpendicular to furring channels with 25mm (1") screws spaced 300mm (12") o.c. Locate screws 19mm (¾") minimum from edges and 50mm (2") from ends of board. Butt joints may be protected by 75mm (3") wide by 12.7mm (½") thick gypsum board back blocking. Joints must be offset. Tape and finish joints with ProRoc products.</p>	<p>FIRE: ULC I506</p> <p>SOUND: Estimated</p>
------------------	--	--	---

## FIRE RESISTANCE RATING: 3 h

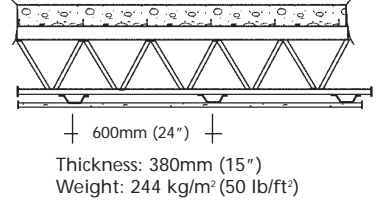
<p><b>57</b></p>	 <p style="text-align: center;">+ 600mm (24") +</p> <p>Thickness: 380mm (15") Weight: 244 kg/m<sup>2</sup> (50 lb/ft<sup>2</sup>)</p>	<p><b>System WFS3A</b> 89mm (3½"), 24 MPa (3500 psi) concrete floor. 12.7mm (½") ProRoc Type C, 1 layer on steel furring channels.</p> <p>Fasten boards perpendicular to furring channels with 25mm (1") screws spaced 300mm (12") o.c. Locate screws 19mm (¾") minimum from edges and 50mm (2") from ends of board. Butt joints may be protected by 75mm (3") wide by 12.7mm (½") thick gypsum board back blocking. Joints must be offset. Tape and finish joints with ProRoc products.</p>	<p>FIRE: ULC I506</p> <p>SOUND: Estimated</p>
------------------	--	--	---

# WOOD JOIST FLOORS & CEILINGS

SOUND TRANSMISSION CLASS (STC)	CONSTRUCTION	DESCRIPTION	DESIGN NUMBER/TEST REPORTS
--------------------------------	--------------	-------------	----------------------------

## FIRE RESISTANCE RATING: 3/4h

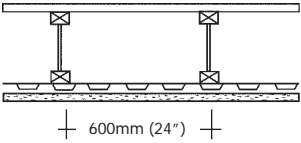
<b>41</b>	 <p style="text-align: center;">+ 600mm (24") +</p> <p>Thickness: 352mm (13 7/8") Weight: 60 kg/m<sup>2</sup> (12 lb/ft<sup>2</sup>)</p>	<p><b>System WFF041A</b> 15.9mm (5/8") ProRoc Type X, 1 layer. 300mm (12") Jager wood I-joists and resilient channels. Subfloor 19mm (3/4") plywood.</p> <p>Fasten boards perpendicular to resilient channels with 32mm (1 1/4") screws spaced 300mm (12") o.c. Locate edge joints between joists. End joints staggered at least 600mm (24"). Locate screws 38mm (1 1/2") from edges and ends of board. Tape and finish joints with ProRoc products.</p>	<p>FIRE: ULC M506</p> <p>SOUND: Estimated</p>
-----------	---	--	---

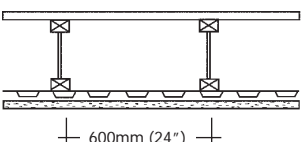
<b>41</b>	 <p style="text-align: center;">+ 600mm (24") +</p> <p>Thickness: 289mm (11 3/8") Weight: 60 kg/m<sup>2</sup> (12 lb/ft<sup>2</sup>)</p>	<p><b>System WFF041B</b> 15.9mm (5/8") ProRoc Type X, 1 layer. 241mm (9 1/2") TJI® wood I-joists and resilient channels. Subfloor 19mm (3/4") OSB.</p> <p>Fasten boards perpendicular to resilient channels with 32mm (1 1/4") screws. Locate edge joints between joists. End joints staggered at least 600mm (24"). Locate 2 rows of screws 19mm (3/4") from edge and 15mm (5/8") from end joints. Tape and finish joints with ProRoc products.</p>	<p>FIRE: ITS TJ/FCA 45-01</p> <p>SOUND: Estimated</p>
-----------	---	--	---

## FIRE RESISTANCE RATING: 1h

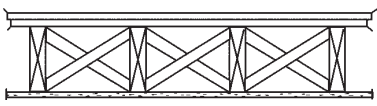
<b>34</b>	 <p style="text-align: center;">+ 400mm (16") +</p> <p>Thickness: 276mm (10 7/8") Weight: 59 kg/m<sup>2</sup> (12 lb/ft<sup>2</sup>)</p>	<p><b>System WFF134</b> 12.7mm (1/2") ProRoc Type C, 1 layer. 38mm x 235mm (2 x 10) wood joist. Subfloor 12mm (1/2") sheathing grade Douglas Fir plywood. Finished floor 15mm (5/8") T&amp;G sheathing Douglas Fir plywood.</p> <p>Fasten boards perpendicular to joists with 44mm (1 3/4") nails spaced 150mm (6") o.c. Locate nails 19mm (3/4") from edge and 15mm (5/8") from end joints. Tape and finish joints with ProRoc products.</p>	<p>FIRE: ULC M502</p> <p>SOUND: Estimated</p>
-----------	--	---	---

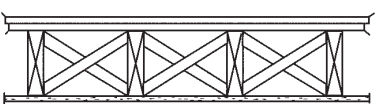
<b>35</b>	 <p style="text-align: center;">+ 400mm (16") +</p> <p>Thickness: 279mm (11") Weight: 64 kg/m<sup>2</sup> (13 lb/ft<sup>2</sup>)</p>	<p><b>System WFF135</b> 15.9mm (5/8") ProRoc Type X, 1 layer. 38mm x 235mm (2 x 10) wood joist. Subfloor 12mm (1/2") sheathing grade Douglas Fir plywood. Finished floor 15mm (5/8") T&amp;G sheathing Douglas Fir plywood.</p> <p>Fasten boards perpendicular to joists with 44mm (1 3/4") nails spaced 150mm (6") o.c. Locate nails 19mm (3/4") from edge and 15mm (5/8") from end joints. Tape and finish joints with ProRoc products.</p>	<p>FIRE: ULC M500</p> <p>SOUND: Estimated</p>
-----------	---	---	---

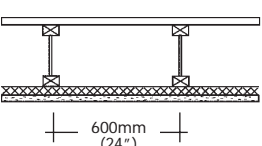
<b>41</b>	 <p style="text-align: center;">+ 600mm (24") +</p> <p>Thickness: 292mm (11 1/2") Weight: 60 kg/m<sup>2</sup> (12 lb/ft<sup>2</sup>)</p>	<p><b>System WFF141A</b> 15.9mm (5/8") ProRoc Type C, 1 layer. 240mm (9 1/2") Jager wood I-joists and hat channels. Subfloor 15.9mm (5/8") T&amp;G waferboard or plywood.</p> <p>Fasten boards perpendicular to furring channels with 42mm (1 3/4") screws spaced 150mm (6") o.c. Locate edge joints between joists. End joints at double row of furring channel and staggered 1200mm (48"). Locate screws 38mm (1 1/2") from edges and ends of board. Tape and finish joints with ProRoc products.</p>	<p>FIRE: ULC M508</p> <p>SOUND: Estimated</p>
-----------	---	---	---

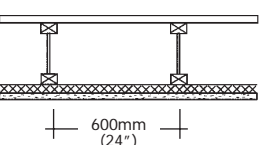
<b>41</b>	 <p style="text-align: center;">+ 600mm (24") +</p> <p>Thickness: 292mm (11 1/2") Weight: 60 kg/m<sup>2</sup> (12 lb/ft<sup>2</sup>)</p>	<p><b>System WFF141B</b> 15.9mm (5/8") ProRoc Type C, 1 layer. 241mm (9 1/2") TJI® wood I-joists with flanges minimum 2 1/2" wide by 1 1/2" deep and hat channels. Subfloor 15.9mm (5/8") OSB or plywood.</p> <p>Fasten boards perpendicular to furring channels with 32mm (1 1/4") screws spaced 150mm (6") o.c. Locate edge joints between joists. End joints at double row of furring channel and staggered 1200mm (48"). Locate screws 76mm (3") from edges and ends of board. Tape and finish joints with ProRoc products.</p>	<p>FIRE: ITS TJ/FCA 60-10</p> <p>SOUND: Estimated</p>
-----------	---	---	---

34

# WOOD JOIST FLOORS & CEILINGS

SOUND TRANSMISSION CLASS (STC)	CONSTRUCTION	DESCRIPTION	DESIGN NUMBER/TEST REPORTS
<b>FIRE RESISTANCE RATING: 1 h (continued)</b>			
<b>42</b>	<p>400mm (16")</p> <p>Thickness: 289mm (11 3/8") Weight: 59 kg/m<sup>2</sup> (12 lb/ft<sup>2</sup>)</p>	<p><b>System WFF142</b> 12.7mm (1/2") ProRoc Type C, 1 layer. 38mm x 235mm (2 x 10) wood joist and resilient channels. Subfloor 12mm (1/2") sheathing grade Douglas Fir plywood. Finished floor 15mm (5/8") T&amp;G sheathing Douglas Fir plywood.</p> <p>Fasten boards perpendicular to resilient channels with 25mm (1") screws spaced 300mm (12") o.c. Locate edge joints between joists. Fasten board end joints to additional pieces of resilient channel extending 150mm (6") beyond end joints and attached to joists. Locate screws 15mm (5/8") from edges and ends of board. Tape and finish joints with ProRoc products.</p>	<p>FIRE: ULC M501 SOUND: Estimated</p>
<b>54</b>	<p>600mm (24")</p> <p>600mm (24")</p> <p>Thickness: 289mm (11 3/8") Weight: 68 kg/m<sup>2</sup> (14 lb/ft<sup>2</sup>)</p>	<p><b>System WFF154</b> 12.7mm (1/2") ProRoc Type C or 15.9mm (5/8") ProRoc Type X 2 layers. Wood joists or wood I-joists, resilient channels and insulation. Subfloor plywood, OSB or waferboard.</p> <p>Fasten base layer perpendicular to furring channels with 32mm (1 1/4") screws spaced 300mm (12") o.c. Locate edge joints between joists. End joints staggered 1200mm (48"). Fasten face layer perpendicular to furring channels with 41mm (1 1/2") screws spaced 300mm (12") o.c. Joints must be staggered. Locate end joints of face layer at double resilient channels. Locate screws 38mm (1 1/2") from edges of board. Tape and finish joints with ProRoc products.</p>	<p>FIRE: NRC 98-764 SOUND: NRC 95-115a</p>
<b>N/A</b>	<p>Gypsum boards applied to underside of wood supports maximum spacing 600mm (24") o.c.</p> <p>Thickness: varies Weight: 22 kg/m<sup>2</sup> (4.6 lb/ft<sup>2</sup>) plus framing</p>	<p><b>System WFF1XX</b> Fire rating provided by membrane only. 15.9mm (5/8") ProRoc Type X, 2 layers. Wood joists any type, resilient or furring channels (optional). Subfloor plywood, OSB or waferboard.</p> <p>Fasten base layer perpendicular to resilient channels with 25mm (1") screws spaced 300mm (12") o.c. Fasten face layer perpendicular to resilient channels with 41mm (1 1/2") screws spaced 300mm (12") o.c. If resilient channels are not used, attach board perpendicular to wood joists with 51mm (2") screws spaced 300mm (12") o.c. for both layers. Joints must be offset. Tape and finish joints with ProRoc products.</p>	<p>FIRE: NBCC (1995) Appendix D Table D.2.3.12 SOUND: –</p>

# WOOD JOIST FLOORS & CEILINGS

**SOUND TRANSMISSION CLASS (STC)**

**CONSTRUCTION**

**DESCRIPTION**

**DESIGN NUMBER/ TEST REPORTS**

**FIRE RESISTANCE RATING: 2h**

**35**

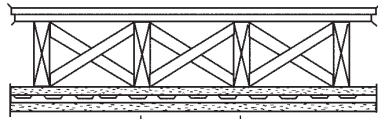

400mm  
(16")

Thickness: 308mm (12 1/8")  
Weight: 78 kg/m<sup>2</sup> (16 lb/ft<sup>2</sup>)

**System WFF235**

15.9mm (5/8") ProRoc Type C, 2 layers. 38mm x 235mm (2 x 10) wood joist and resilient channels. Subfloor 12mm (1/2") sheathing grade Douglas Fir plywood. Finished floor 15.9mm (5/8") T&G sheathing Douglas Fir plywood.

Fasten base layer perpendicular to joists with 63mm (2 1/2") 8d box nails spaced 175mm (7") o.c. Locate nails a minimum 15mm (5/8") from edges of boards. Attach resilient channels perpendicular to joists 600mm (24") o.c. with 64mm (2 1/2") 8d common nails. Provide a 102mm (4") overlap at splices and a minimum 19mm (3/4") wall clearance. Fasten face layer perpendicular to resilient channels with 25mm (1") screws spaced 300mm (12") o.c. Located edge joints between joists and fasten end joints of boards to additional pieces of resilient channel extending 150mm (6") beyond end joints and attached to joists. Locate screws a minimum 25mm (1") from edges of board. Tape and finish joints with ProRoc products.

FIRE: ULC M503  
SOUND: Estimated

**37**

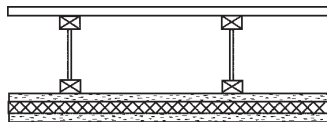

600mm (24")

Thickness: 305mm (12")  
Weight: 68 kg/m<sup>2</sup> (14 lb/ft<sup>2</sup>)

**System WFF237**

15.9mm (5/8") ProRoc Type C, 2 layers. 240mm (9 1/2") Jager wood I-joists and hat channels. Subfloor 15.9mm (5/8") waferboard or plywood.

Fasten base layer perpendicular to joists with 42mm (1 5/8") screws spaced 150mm (6") o.c. Locate screws 38mm (1 1/2") from edges and ends of boards. Attach furring channels perpendicular to joists 400mm (16") o.c. with two 42mm (1 5/8") screws at each I-joist. Locate a continuous double row of furring channel 1200mm (48") o.c. Fasten face layer perpendicular to furring channels with 42mm (1 5/8") screws spaced 150mm (6") o.c. Locate edge joints between I-joists and end joints at double row of furring channel. Locate screws a minimum 38mm (1 1/2") from edges of board. End joints must be staggered 1200mm (48"). Tape and finish joints with ProRoc products.

FIRE: ULC M508  
SOUND: Estimated

**40**

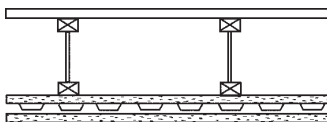

600mm (24")

Thickness: 321mm (12 5/8")  
Weight: 78 kg/m<sup>2</sup> (16 lb/ft<sup>2</sup>)

**System WFF240**

15.9mm (5/8") ProRoc Type C, 3 layers. 241mm (9 1/2") TJI® wood I-joists and resilient channels. Subfloor 15.9mm (5/8") OSB plywood.

Fasten base layer perpendicular to joists with 41mm (1 5/8") screws spaced 200mm (8") o.c. Attach furring channels perpendicular to joists 400mm (16") o.c. with 48mm (1 7/8") screws at each I-joist. Fasten second layer perpendicular to furring channel with 32mm (1 1/4") screws spaced 200mm (8") o.c. and edges of board located between floor I-joists. Fasten face layer perpendicular to furring channels with 48mm (1 7/8") screws spaced 200mm (8") o.c. with joints offset. Locate screws 38mm (1 1/2") from edges and 19mm (3/4") from ends of boards. End joints must be staggered. Tape and finish joints with ProRoc products.

FIRE: ITS TJ/FCA 120-03  
SOUND: Estimated

# COLUMN & BEAM PROTECTION

**SOUND TRANSMISSION CLASS (STC)**

**CONSTRUCTION**

**DESCRIPTION**

**DESIGN NUMBER/ TEST REPORTS**

## FIRE RESISTANCE RATING: 1h

### Column

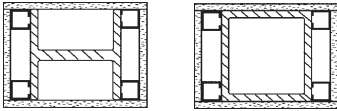

Minimum W200 x 46 (W8 x 31) or HSS -M/D 55 steel column.  
Weight: 15 kg/m<sup>2</sup> (3 lb/ft<sup>2</sup>)

### System WC1A

15.9mm (5/8") ProRoc Type X, 1 layer. 41mm (1 1/8") steel studs positioned at column corners, 12.7mm (1/2") less than column height. Install board vertically with 25mm (1") screws spaced 300mm (12") o.c. Apply corner bead with 25mm (1") screws spaced 300mm (12") o.c. Tape and finish joints with ProRoc products.

FIRE: NBCC (1995)  
  
Appendix D  
Table D-2.6.1.F.  
(see also ULI X528)

## FIRE RESISTANCE RATING: 2h

### Beam

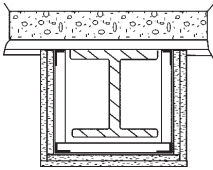

Minimum W200 x 36 (W8 x 24) steel beam.  
Weight: 29 kg/m<sup>2</sup> (6 lb/ft<sup>2</sup>)

### System WB2A

15.9mm (5/8") ProRoc Type X, 2 layers. 43mm x 25mm (1 1/16" x 1") steel channels and 25mm x 50mm (1" x 2") steel angles.

Leave a minimum 13mm (1/2") clearance at sides and bottom of beam. Attach angle to steel deck with 12mm (1/2") Phillips pan head screws spaced 300mm (12") o.c. Attach channel brackets to angle 600mm (24") o.c. with 12mm (1/2") Phillips pan head screws. Attach steel angle to lower corners of U-brackets with 12mm (1/2") Phillips pan head screws at 400mm (16") o.c. Install base layer of board with 32mm (1 1/4") screws spaced 400mm (16") o.c. Install face layer with 44mm (1 3/4") screws spaced 200mm (8") o.c. Joints must be offset. Attach corner bead, tape and finish joints with ProRoc products.

FIRE: ULC O501

### Beam

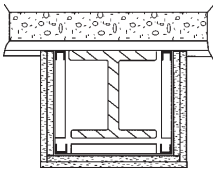

Minimum W200 x 36 (W8 x 24) steel beam.  
Weight: 29 kg/m<sup>2</sup> (6 lb/ft<sup>2</sup>)

### System WB2B

15.9mm (5/8") ProRoc Type X, 2 layers. 43mm x 25mm (1 1/16" x 1") steel channels.

Leave a minimum 13mm (1/2") clearance at sides and bottom of beam. Attach angle to steel deck with 12mm (1/2") Phillips pan head screws spaced 300mm (12") o.c. Attach channel brackets to angle 600mm (24") o.c. with 12mm (1/2") Phillips pan head screws. Insert channel angle in bracket, screw attachment is not required. Install base layer of board with 32mm (1 1/4") screws spaced 400mm (16") o.c. Install face layer with 44mm (1 3/4") screws spaced 200mm (8") o.c. Joints must be offset. Attach corner bead, tape and finish joints with ProRoc products.

FIRE: ULC O502

### Column

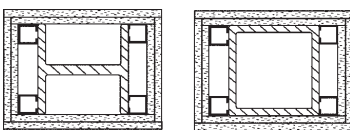

Minimum W250 x 73 (W10 x 49) steel column.  
Weight: 29 kg/m<sup>2</sup> (6 lb/ft<sup>2</sup>)

### System WC2A

15.9mm (5/8") ProRoc Type X, 2 layers. 41mm (1 5/8") steel studs positioned at column corners, 12.7mm (1/2") less than column height. Install base layer of board vertically with 25mm (1") screws spaced 600mm (24") o.c. Install face layer vertically with 44mm (1 3/4") screws spaced 300mm (12") o.c. Apply corner bead with 41mm (1 5/8") screws spaced 300mm (12") o.c. Tape and finish joints with ProRoc products.

FIRE: NBCC (1995)

Appendix D  
Table D-2.6.1.F.  
(see also ULI X528)

## FIRE RESISTANCE RATING: 3h

### Column

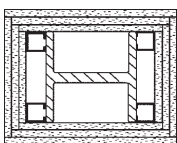

Minimum W250 x 73 (W10 x 49) steel column.  
Weight: 39 kg/m<sup>2</sup> (8 lb/ft<sup>2</sup>)

### System WC3A

15.9mm (5/8") ProRoc Type X, 3 layers. 41mm (1 5/8") steel studs positioned at column corners, 12.7mm (1/2") less than column height. Install base layer of board vertically with 25mm (1") screws spaced 600mm (24") o.c. Install second layer vertically with 44mm (1 3/4") screws spaced 300mm (12") o.c. Install face layer vertically with 57mm (2 1/4") No. 8 screws spaced 300mm (12") o.c. Apply corner bead with 51mm (2") 6d nails spaced 300mm (12") o.c. Tape and finish joints with ProRoc products.

FIRE: ULC Z502

# CONCRETE BLOCK/GYPSUM BOARD WALLS

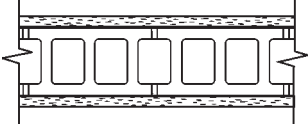
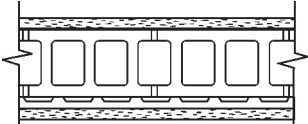
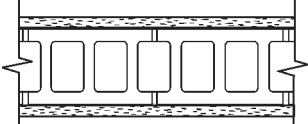
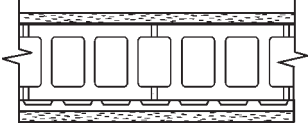
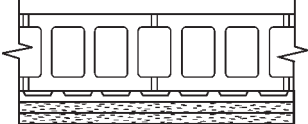
SOUND TRANSMISSION CLASS (STC)	CONSTRUCTION	DESCRIPTION	DESIGN NUMBER/ TEST REPORTS
<b>FIRE RESISTANCE RATING: 2h</b>			
<b>47</b>		<p><b>System WBA247</b> 140mm (nominal 6") concrete block, 15.9mm (5/8") ProRoc Type X, 1 layer, directly applied each side.</p> <p>Install board vertically or horizontal to each side with adhesive or mechanical fasteners. Tape and finish joints with ProRoc products.</p>	<p>FIRE: NBCC (1995) Table A-9.10.3.1.A Wall B2b</p> <p>SOUND: NBCC (1995) Table A-9.10.3.1.A Wall B2b</p>
<b>51</b>		<p><b>System WBA251</b> 140mm (nominal 6") concrete block, 15.9mm (5/8") ProRoc Type X, 1 layer, directly applied one side. Other side, 1 layer on resilient channels.</p> <p>Install board on one side vertically or horizontally with adhesive or mechanical fasteners. Attach resilient channels horizontally at 600mm (24") o.c. or 400mm (16") o.c. to other side of the block wall. Install mineral fibre insulation in the furred space and fasten board vertically or horizontally to the resilient channels with 25mm (1") screws spaced 300mm (12") o.c. Tape and finish joints with ProRoc products.</p>	<p>FIRE: NBCC (1995) Table A-9.10.3.1.A Wall B3a</p> <p>SOUND: NBCC (1995) Table A-9.10.3.1.A Wall B3a</p>
<b>FIRE RESISTANCE RATING: 3h</b>			
<b>50</b>		<p><b>System WBB350</b> 190mm (nominal 8") concrete block, 15.9mm (5/8") ProRoc Type X, 1 layer, directly applied each side.</p> <p>Install board vertically or horizontal to each side with adhesive or mechanical fasteners. Tape and finish joints with ProRoc products.</p>	<p>FIRE: NBCC (1995) Table A-9.10.3.1.A Wall B2e</p> <p>SOUND: NBCC (1995) Table A-9.10.3.1.A Wall B2e</p>
<b>54</b>		<p><b>System WBB354</b> 190mm (nominal 8") concrete block, 15.9mm (5/8") ProRoc Type X, 1 layer, directly applied one side. Other side, 1 layer on resilient channel.</p> <p>Install board on one side vertically or horizontally with adhesive or mechanical fasteners. Attach resilient channels horizontally at 600mm (24") o.c. or 400mm (16") o.c. to other side of the block wall. Install mineral fibre insulation in the furred space and fasten board vertically or horizontally to the resilient channels with 25mm (1") screws spaced 300mm (12") o.c. Tape and finish joints with ProRoc products.</p>	<p>FIRE: NBCC (1995) Table A-9.10.3.1.A Wall B3c</p> <p>SOUND: NBCC (1995) Table A-9.10.3.1.A Wall B3c</p>
<b>56</b>		<p><b>System WBB356</b> 190mm (nominal 8") concrete block, 15.9mm (5/8") ProRoc Type X, 2 layers, on resilient channel, 1 side.</p> <p>Attach resilient channels horizontally at 600mm (24") o.c. or 400mm (16") o.c. to one side of the block wall. Install mineral fibre insulation in the furred space and fasten base layer of board vertically or horizontally to the resilient channels with 25mm (1") screws spaced 300mm (12") o.c. Install face layer of board vertically or horizontally to resilient channel with 41mm (1 1/2") screws spaced 300mm (12") o.c. Joints must be offset. Tape and finish joints with ProRoc products.</p>	<p>FIRE: NBCC (1995) Table A-9.10.3.1.A Wall B10a</p> <p>SOUND: NBCC (1995) Table A-9.10.3.1.A Wall B10a</p>

# STEEL STUD PERMABASE PARTITIONS

## Non-load bearing

SOUND TRANSMISSION CLASS (STC)	CONSTRUCTION	DESCRIPTION	DESIGN NUMBER/TEST REPORTS
--------------------------------	--------------	-------------	----------------------------

### FIRE RESISTANCE RATING: 1h

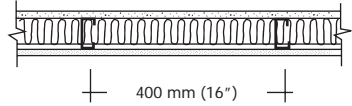
<b>51</b>	 <p data-bbox="194 504 438 567">Thickness: 121 mm (4 3/4") Weight: 31 kg/m<sup>2</sup> (6.4 lb/ft<sup>2</sup>)</p>	<p data-bbox="597 388 787 420"><b>System PPC151</b></p> <p data-bbox="597 420 1274 661">Fasten 12.7mm (1/2") PermaBase horizontally to one side of the 92mm (3 5/8") steel studs using 25mm (1") screws spaced 150mm (6") o.c. on the perimeter and 200mm (8") o.c. in the field. Install 89mm (3 1/2") minimum 28 kg/m<sup>3</sup> (1.75 lb/ft<sup>3</sup>) mineral wool insulation in the cavity. Fasten 15.9mm (5/8") ProRoc Type X board vertically to the other side with 25mm (1") screws spaced 300mm (12") o.c. All joints must be staggered a minimum of 300mm (12"). Tape and finish PermaBase joints with fiberglass mesh joint tape and latex-modified Portland cement mortar applied at a minimum rate of 2.7 kg/m<sup>2</sup> (0.55 lb/ft<sup>2</sup>). Tape and finish ProRoc Type X joints with ProRoc products.</p>	<p data-bbox="1323 388 1453 420">FIRE: ULC W438</p> <p data-bbox="1323 441 1437 493">SOUND: NRC CR-6466.1</p>
-----------	---	--	---

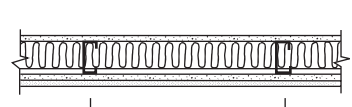
<b>55</b>	 <p data-bbox="194 829 438 882">Thickness: 130 mm (5 1/8") Weight: 38 kg/m<sup>2</sup> (7.8 lb/ft<sup>2</sup>)</p>	<p data-bbox="597 682 787 724"><b>System PPC155</b></p> <p data-bbox="597 724 1274 1060">Fasten 12.7mm (1/2") ProRoc Type C board vertically or horizontally to one side of 92mm (3 5/8") steel studs using 25mm (1") screws spaced 200mm (8") on the perimeter and 300mm (12") o.c. in the field. Fasten a face layer of 12.7mm (1/2") PermaBase horizontally to the same side using 41mm (1 1/8") screws spaced 150mm (6") o.c. on the perimeter and 200mm (8") o.c. in the field. Install 89mm (3 1/2") minimum 28 kg/m<sup>3</sup> (1.75 lb/ft<sup>3</sup>) mineral wool insulation in the cavity. Fasten 12.7mm (1/2") ProRoc Type C board vertically to the other side with 25mm (1") screws spaced 200mm (8") on the perimeter and 300mm (12") o.c. in the field. All joints must be staggered a minimum of 300mm (12"). Tape and finish PermaBase joints with fiberglass mesh joint tape and latex-modified Portland cement mortar applied at a minimum rate of 2.7 kg/m<sup>2</sup> (0.55 lb/ft<sup>2</sup>). Tape and finish outer layer ProRoc Type C joints with ProRoc products.</p>	<p data-bbox="1323 682 1453 724">FIRE: ULC W437</p> <p data-bbox="1323 745 1437 808">SOUND: NRC CR-6466.6</p>
-----------	---	---	---

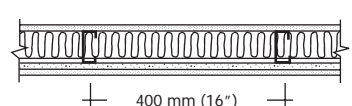
<b>59</b>	 <p data-bbox="194 1218 446 1270">Thickness: 130 mm (5 1/8") Weight: 44 kg/m<sup>2</sup> (9.0 lb/ft<sup>2</sup>)</p>	<p data-bbox="597 1081 787 1123"><b>System PPC159</b></p> <p data-bbox="597 1123 1274 1396">Fasten 12.7mm (1/2") ProRoc Type C board vertically or horizontally to one side of 92mm (3 5/8") steel studs using 25mm (1") screws spaced 300mm (12") o.c. Fasten a face layer of 12.7mm (1/2") PermaBase horizontally to the same side using 41mm (1 1/8") screws spaced 150mm (6") on the perimeter and 200mm (8") o.c. in the field. Install 89mm (3 1/2") minimum 28 kg/m<sup>3</sup> (1.75 lb/ft<sup>3</sup>) mineral wool insulation in the cavity. Fasten 12.7mm (1/2") PermaBase horizontally to the other side with 25mm (1") screws spaced 150mm (6") on the perimeter and 200mm (8") o.c. in the field. All joints must be staggered a minimum of 300mm (12"). Tape and finish PermaBase joints with fiberglass mesh joint tape and latex-modified Portland cement mortar applied at a minimum rate of 2.7 kg/m<sup>2</sup> (0.55 lb/ft<sup>2</sup>).</p>	<p data-bbox="1323 1081 1453 1123">FIRE: ULC W436</p> <p data-bbox="1323 1144 1437 1197">SOUND: NRC CR-6466.3</p>
-----------	---	---	---

### FIRE RESISTANCE RATING: 2h

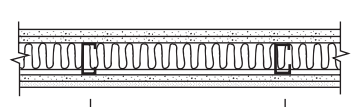
<b>59</b>	 <p data-bbox="194 1617 446 1669">Thickness: 143 mm (5 5/8") Weight: 47 kg/m<sup>2</sup> (9.6 lb/ft<sup>2</sup>)</p>	<p data-bbox="597 1480 787 1522"><b>System PPC259</b></p> <p data-bbox="597 1522 1274 1869">Fasten 12.7mm (1/2") ProRoc Type C board vertically or horizontally to one side of 92mm (3 5/8") steel studs using 25mm (1") screws spaced 300mm (12") o.c. Fasten a face layer of 12.7mm (1/2") PermaBase horizontally to the same side using 41mm (1 1/8") screws spaced 230mm (9") o.c. Joints must be staggered a minimum of 300mm (12") from joints in the base layer. Install 89mm (3 1/2") minimum 28 kg/m<sup>3</sup> (1.75 lb/ft<sup>3</sup>) mineral wool insulation in the cavity. Fasten 12.7mm (1/2") ProRoc Type C board vertically or horizontally to other side using 25mm (1") screws spaced 300mm (12") o.c. Fasten a face layer of 12.7mm (1/2") ProRoc Type C vertically or horizontally to the same side using 41mm (1 1/8") screws spaced 230mm (9") o.c. Joints must be staggered a minimum of 600mm (24") from joints in the base layer. Tape and finish PermaBase joints with fiberglass mesh joint tape and latex-modified Portland cement mortar applied at a minimum rate of 2.7 kg/m<sup>2</sup> (0.55 lb/ft<sup>2</sup>). Tape and finish outer layer ProRoc Type C joints with ProRoc products.</p>	<p data-bbox="1323 1480 1453 1522">FIRE: ULC W439</p> <p data-bbox="1323 1543 1437 1596">SOUND: NRC CR-6466.4</p>
-----------	---	--	---

# STEEL STUD PERMABASE PARTITIONS

## Non-load bearing

SOUND TRANSMISSION CLASS (STC)	CONSTRUCTION	DESCRIPTION	DESIGN NUMBER/TEST REPORTS
--------------------------------	--------------	-------------	----------------------------

### FIRE RESISTANCE RATING: 2h (continued)

**61**

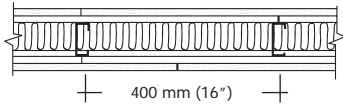

Thickness: 143 mm (5 5/8")  
Weight: 53 kg/m<sup>2</sup> (11 lb/ft<sup>2</sup>)

#### System PPC261

Fasten 12.7mm (1/2") ProRoc Type C board vertically or horizontally to each side of 92mm (3 5/8") steel studs using 25mm (1") screws spaced 300mm (12") o.c. Fasten a face layer of 12.7mm (1/2") Permabase horizontally to each side using 41mm (1 3/8") screws spaced 230mm (9") o.c. Install 89mm (3 1/2") minimum 28 kg/m<sup>3</sup> (1.75 lb/ft<sup>3</sup>) mineral wool insulation in the cavity. All joints must be staggered a minimum of 300mm (12"). Tape and finish Permabase joints with fiberglass mesh joint tape and latex-modified Portland cement mortar applied at a minimum rate of 2.7 kg/m<sup>2</sup> (0.55 lb/ft<sup>2</sup>).

FIRE: ULC W439

SOUND: NRC  
CR-6466.5

# STEEL STUD PERMABASE PARTITIONS

## (CHASE WALL)\* Non-load bearing

### FIRE RESISTANCE RATING: 1h

**53**

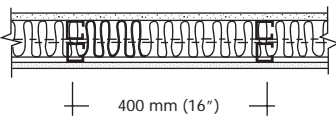

Thickness: 121 mm (4 3/4")  
Weight: 33 kg/m<sup>2</sup> (6.7 lb/ft<sup>2</sup>)

#### System PPA153

Position paired 41mm (1 5/8") steel studs and track a minimum of 9.5mm (3/8") apart. Maintain separation between paired steel studs by attaching steel stud bridging 760mm (30") o.c. to steel stud webs using self-drilling, self-tapping screws (two per stud).

Fasten 12.7mm (1/2") Permabase horizontally to one side using 25mm (1") screws spaced 150mm (6") o.c. on the perimeter and 200mm (8") o.c. in the field. Install 89mm (3 1/2") minimum 28 kg/m<sup>3</sup> (1.75 lb/ft<sup>3</sup>) mineral wool insulation in the cavity. Fasten 15.9mm (5/8") ProRoc Type X board vertically to the other side with 25mm (1") screws spaced 300mm (12") o.c. All joints must be staggered a minimum of 300mm (12"). Tape and finish Permabase joints with fiberglass mesh joint tape and latex-modified Portland cement mortar applied at a minimum rate of 2.7 kg/m<sup>2</sup> (0.55 lb/ft<sup>2</sup>). Tape and finish ProRoc Type X joints with ProRoc products.

FIRE: ULC W438

SOUND: Estimate based on NRC  
CR-6466.1

**57**

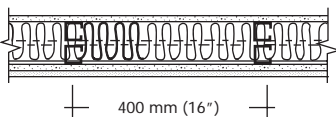

Thickness: 130 mm (5 1/8")  
Weight: 40 kg/m<sup>2</sup> (8.1 lb/ft<sup>2</sup>)

#### System PPA157

Position paired 41mm (1 5/8") steel studs and track a minimum of 9.5mm (3/8") apart. Maintain separation between paired steel studs by attaching steel stud bridging 760mm (30") o.c. to steel stud webs using self-drilling, self-tapping screws (two per stud).

Fasten 12.7mm (1/2") ProRoc Type C board vertically or horizontally to one side using 25mm (1") screws spaced 200mm (8") on the perimeter and 300mm (12") o.c. in the field. Fasten a face layer of 12.7mm (1/2") Permabase horizontally to the same side using 41mm (1 3/8") screws spaced 150mm (6") o.c. on the perimeter and 200mm (8") o.c. in the field. Install 89mm (3 1/2") minimum 28 kg/m<sup>3</sup> (1.75 lb/ft<sup>3</sup>) mineral wool insulation in the cavity. Fasten 12.7mm (1/2") ProRoc Type C board vertically to the other side with 25mm (1") screws spaced 200mm (8") on the perimeter and 300mm (12") o.c. in the field. All joints must be staggered a minimum of 300mm (12"). Tape and finish Permabase joints with fiberglass mesh joint tape and latex-modified Portland cement mortar applied at a minimum rate of 2.7 kg/m<sup>2</sup> (0.55 lb/ft<sup>2</sup>). Tape and finish outer layer ProRoc Type C joints with ProRoc products.

FIRE: ULC W437

SOUND: NRC  
CR-6466.8

# STEEL STUD PERMABASE PARTITIONS (CHASE WALL)\* Non-load bearing

SOUND  
TRANSMISSION  
CLASS (STC)

CONSTRUCTION

DESCRIPTION

DESIGN NUMBER/  
TEST REPORTS

## FIRE RESISTANCE RATING: 1h (continued)

60

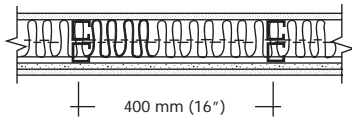

Thickness: 130 mm (5 1/8")  
Weight: 45 kg/m<sup>2</sup> (9.3 lb/ft<sup>2</sup>)

### System PPA160

Position paired 41mm (1 5/8") steel studs and track a minimum of 9.5mm (3/8") apart. Maintain separation between paired steel studs by attaching steel stud bridging 760mm (30") o.c. to steel stud webs using self-drilling, self-tapping screws (two per stud).

Fasten 12.7mm (1/2") ProRoc Type C board vertically or horizontally to one side using 25mm (1") screws spaced 300mm (12") o.c. Fasten a face layer of 12.7mm (1/2") Permabase horizontally to the same side using 41mm (1 5/8") screws spaced 150mm (6") on the perimeter and 200mm (8") o.c. in the field. Install 89mm (3 1/2") minimum 28 kg/m<sup>3</sup> (1.75 lb/ft<sup>3</sup>) mineral wool insulation in the cavity. Fasten 12.7mm (1/2") Permabase horizontally to the other side with 25mm (1") screws spaced 150mm (6") on the perimeter and 200mm (8") o.c. in the field. All joints must be staggered a minimum of 300mm (12"). Tape and finish Permabase joints with fiberglass mesh joint tape and latex-modified Portland cement mortar applied at a minimum rate of 2.7 kg/m<sup>2</sup> (0.55 lb/ft<sup>2</sup>).

FIRE: ULC W436

SOUND: NRC  
CR-6466.7

## FIRE RESISTANCE RATING: 2h

61

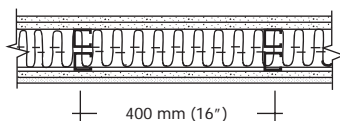

Thickness: 143 mm (5 5/8")  
Weight: 48 kg/m<sup>2</sup> (9.9 lb/ft<sup>2</sup>)

### System PPA261

Position paired 41mm (1 5/8") steel studs and track a minimum of 9.5mm (3/8") apart. Maintain separation between paired steel studs by attaching steel stud bridging 760mm (30") o.c. to steel stud webs using self-drilling, self-tapping screws (two per stud).

Fasten 12.7mm (1/2") ProRoc Type C board vertically or horizontally to one side using 25mm (1") screws spaced 300mm (12") o.c. Fasten a face layer of 12.7mm (1/2") Permabase horizontally to the same side using 41mm (1 5/8") screws spaced 230mm (9") o.c. Joints must be staggered a minimum of 300mm (12") from joints in the base layer. Install 89mm (3 1/2") minimum 28 kg/m<sup>3</sup> (1.75 lb/ft<sup>3</sup>) mineral wool insulation in the cavity. Fasten 12.7mm (1/2") ProRoc Type C board vertically or horizontally to other side using 25mm (1") screws spaced 300mm (12") o.c. Fasten a face layer of 12.7mm (1/2") ProRoc Type C vertically or horizontally to the same side using 41mm (1 5/8") screws spaced 230mm (9") o.c. Joints must be staggered a minimum of 600mm (24") from joints in the base layer. Tape and finish Permabase joints with fiberglass mesh joint tape and latex-modified Portland cement mortar applied at a minimum rate of 2.7 kg/m<sup>2</sup> (0.55 lb/ft<sup>2</sup>). Tape and finish outer layer ProRoc Type C joints with ProRoc products.

FIRE: ULC W439

SOUND: NRC  
CR-6466.9

63

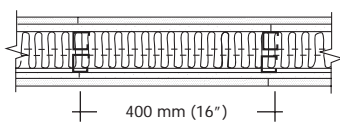

Thickness: 143 mm (5 5/8")  
Weight: 54 kg/m<sup>2</sup> (11 lb/ft<sup>2</sup>)

### System PPA263

Position paired 41mm (1 5/8") steel studs and track a minimum of 9.5mm (3/8") apart. Maintain separation between paired steel studs by attaching steel stud bridging 760mm (30") o.c. to steel stud webs using self-drilling, self-tapping screws (two per stud).

Fasten 12.7mm (1/2") ProRoc Type C board vertically or horizontally to each side using 25mm (1") screws spaced 300mm (12") o.c. Fasten a face layer of 12.7mm (1/2") Permabase horizontally to each side using 41mm (1 5/8") screws spaced 230mm (9") o.c. Install 89mm (3 1/2") minimum 28 kg/m<sup>3</sup> (1.75 lb/ft<sup>3</sup>) mineral wool insulation in the cavity. All joints must be staggered a minimum of 300mm (12"). Tape and finish Permabase joints with fiberglass mesh joint tape and latex-modified Portland cement mortar applied at a minimum rate of 2.7 kg/m<sup>2</sup> (0.55 lb/ft<sup>2</sup>).

FIRE: ULC W439

SOUND: NRC  
CR-6466.10

\* Chase Wall Partitions provide a space in the partition cavity to accommodate plumbing, electrical and other services.

---

Distributed By:

**CertainTeed** 

**CertainTeed Corporation**  
**P.O. Box 860**  
**Valley Forge, PA 19482**

**Professional: 800-233-8990**  
**Consumer: 800-782-8777**  
**[www.certainteed.com](http://www.certainteed.com)**

Characteristics, properties or performance of materials or systems manufactured by CertainTeed herein described are derived from data obtained under controlled test conditions. CertainTeed makes no warranties, express or implied, as to their characteristics, properties or performance under any variations from such conditions in actual construction. CertainTeed assumes no responsibility for the effects of structural movement.

<sup>TM</sup>® CertainTeed and the tag line "Quality made certain. Satisfaction guaranteed." are trademarks of CertainTeed Corporation. All other trademarks are the property of BPB plc or its affiliates and related companies.

NOTICE: The information in this document is subject to change without notice. CertainTeed assumes no responsibility for any errors that may inadvertently appear in this document.

©01/07 CertainTeed Corporation. Printed in Canada on recycled paper. ♻ March 2007 Form #: L-MN-001-E