

CertainTeed

4" Certa-Lok™ Ball Valve

Ready-to-Install

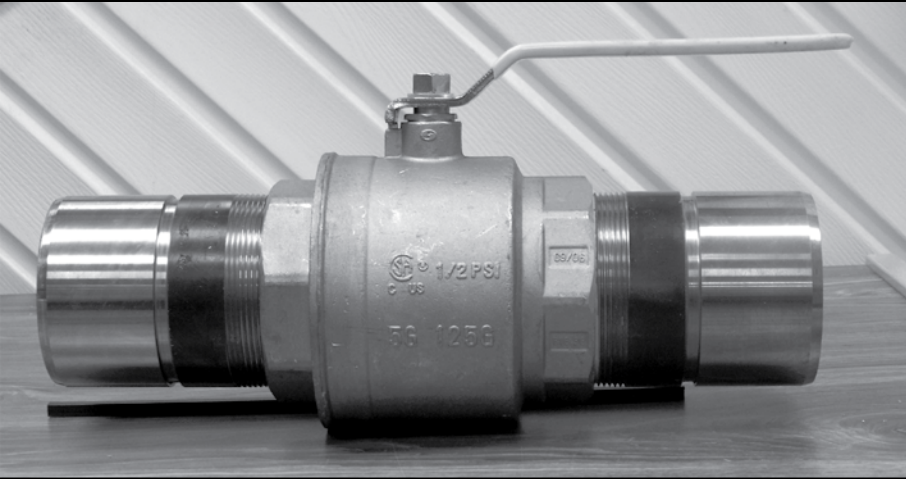

Valve Description:

4" Forged Brass Ball Valve, full-port with chrome plated ball and steel handle. Chrome plated brass stem, blow-out proof with adjustable packing nut. Heavy wall, alloy steel nipples per ASTM A513.

This is a ready-to-install valve assembly and is intended only for mining applications. The assembly is tested for use with 4" Certa-Lok™ Yelomine™ pipe. (Yelomine™ part numbers: 250217, 218217).

Product Features:

Size (In.)	Pressure Rating (psi)**	Material	Weight (lbs)	Temperature Range	Part No.
4"	400	Brass & Steel	27	0°F - 400°F	860973

*All dimensions and weights are subject to normal manufacturing tolerances

**When used with Certa-Lok Yelomine Pipe, the overall pressure rating of the system will be limited by the lowest rating on any of the system components.

Dimensions:

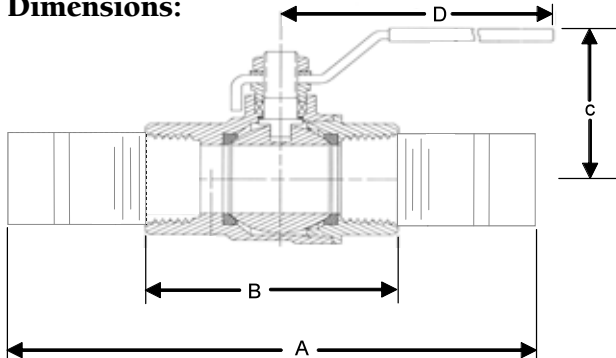

A	B	C	D
17.5"	7.39"	5.87"	9.61"

Packaging: Certa-Lok Ball Valve is sold and shipped in 25-unit bulk packs.

ASK ABOUT ALL OF OUR OTHER CERTAINTEED® PRODUCTS AND SYSTEMS:

ROOFING • SIDING • TRIM • WINDOWS • DECKING • RAILING • FENCE
INSULATION • GYPSUM • CEILINGS • FOUNDATIONS • PIPE

CertainTeed Corporation
P.O. Box 860
Valley Forge, PA 19482

Phone: 866-CT4-PIPE

www.certainteed.com

<http://blog.certainteed.com>

© 05/10 CertainTeed Corporation, Printed in the U.S.A.
Code No. 40-90-65