

Installation Guide for
FlintEdge Fascia ET
(For Built Up and Modified Roofs)

ANSI/SPRI ES-1 TESTED

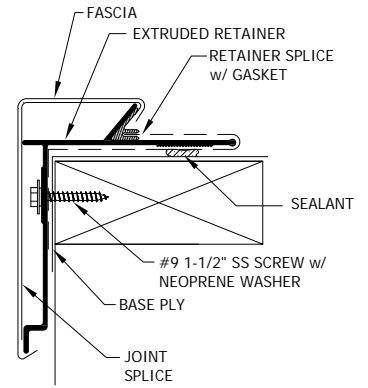

NOTES:

#1 - Isolate all metal parts from ACQ treated wood or other galvanically incompatible material with appropriate membrane material.
#2 - Appliance attachments, such as lightning rods, signs, or antennae that penetrate the water seal, induce a galvanic reaction, or otherwise compromise the effectiveness of the roof edge system, shall be eliminated or isolated to prevent problems per section 8.0 of ANSI/SPRI ES-1. Appliances should be isolated from or not attached to the roof edge system. Consult the lightning protection system manufacturer for specific attachment instructions.

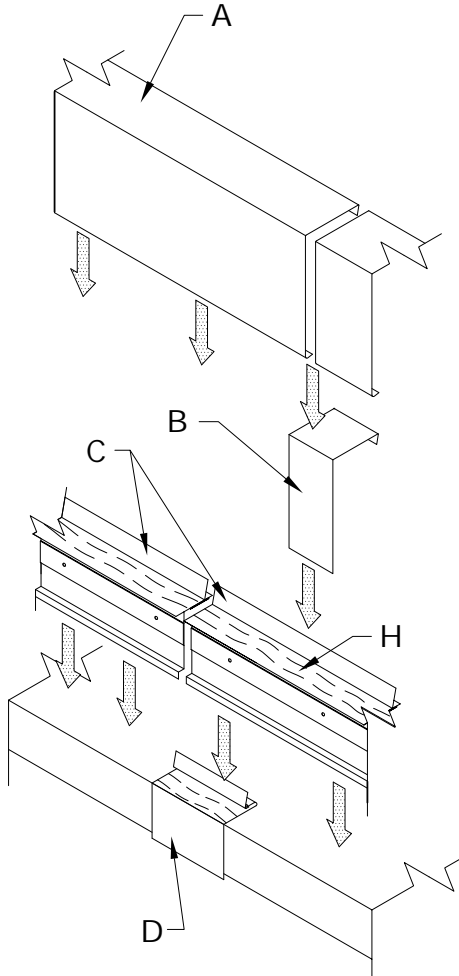

- A. Fascia Cover
10'-0" Lengths
- B. Concealed Joint Splice
4" Lengths
- C. Extruded Retainer
10'-0" Lengths
- D. Retainer Splice With Gasket
6" Lengths
- E. Corner Fascia Cover
(Outside Corner Shown)

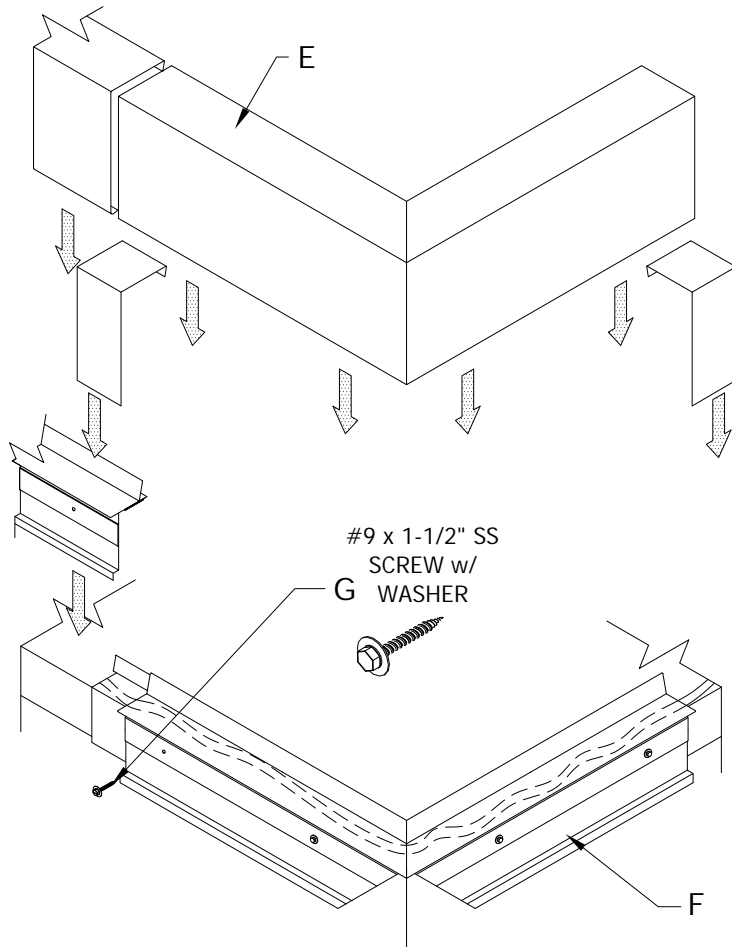

- F. Extruded Retainer Corner
(Outside Corner Shown)
- G. #9 x 1-1/2" SS Screw w/ Neoprene Washer
at 12" o.c. (6" from ends)
(Included & Required)
- H. Non-Hardening Sealant
Continuous Bead of Sealant
(By Installer)

CERTAINTEED ROOFING

750 E. Swedesford Road - Valley Forge, PA 19482 - Phone: (800) 345-1145

www.certainteed.com

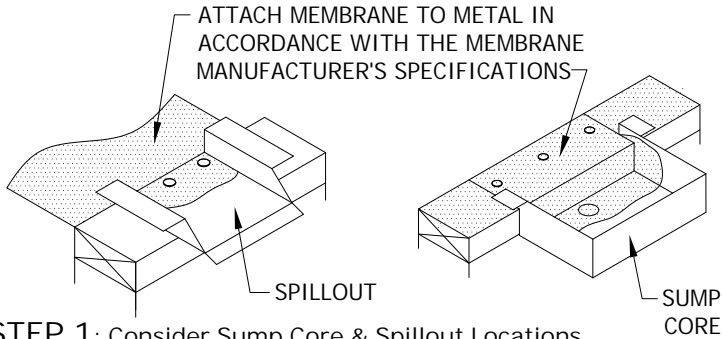

STEP 1: Consider Sump Core & Spillout Locations

Locate sump cores where downspouts will be located. Sumps are installed prior to the retainer. The retainer butts up to side(s) of sump box. Spillouts are installed along with the fascia lengths. Refer to "Spillout & Sump Core Install Guides" for more info on installation if necessary.

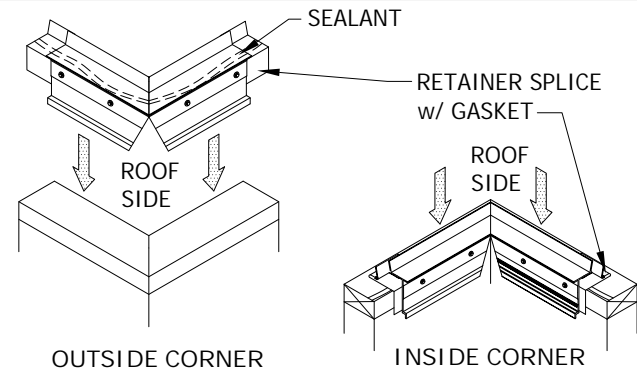

STEP 2: Installing Retainer Miters

Locate retainer miter for each corner. Apply a continuous bead of the roofing manufacturer's sealant to the bottom side of the retainer miter. Locate a retainer splice into each end of the retainer miter. Place two screws (included) in each side of the corner support.

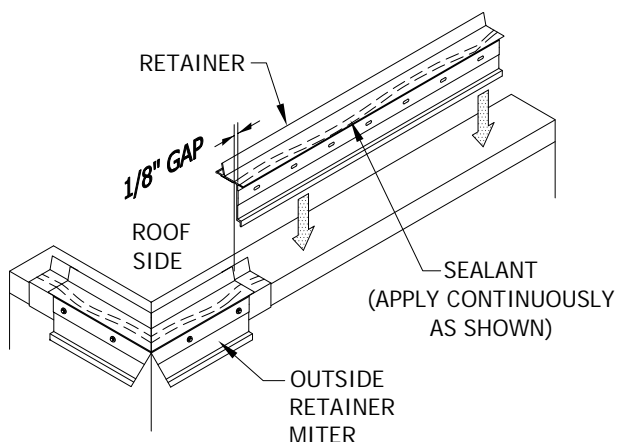

STEP 3: Installing Retainer

Apply a continuous bead of the roofing manufacturer's sealant to the bottom side of the retainer (see first page for detail view). Set the retainer onto the roof edge over membrane; install a retainer splice on end opposite of retainer miter. Attach retainer using mechanical screw fasteners (included). Locate fasteners in each of the pre-punched holes. Allow 1/8" gap between the retainer sections for thermal expansion (1/4" if temperature is below 40°F).

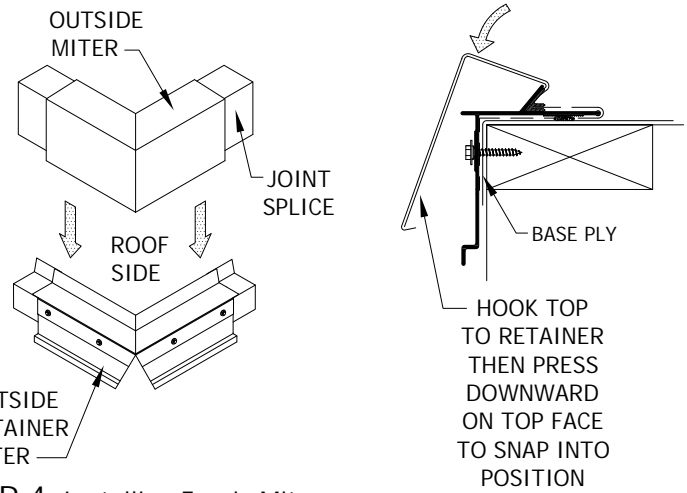

STEP 4: Installing Fascia Miters

Locate concealed joint splices on both ends of the fascia miters (as shown). Leave approximately 1/2 of the joint splice extending past the end of the miter leg. With splices inside of miter, hook the top flange of the miter onto the top flange of the retainer to engage the top. Once the top of the miter has been engaged to the top of the retainer, rotate the fascia outward towards the outside of the building and press down on the top flange of the fascia to snap the bottom hook onto the bottom of the retainer. Make sure that the hook of the fascia has fully engaged onto the retainer.

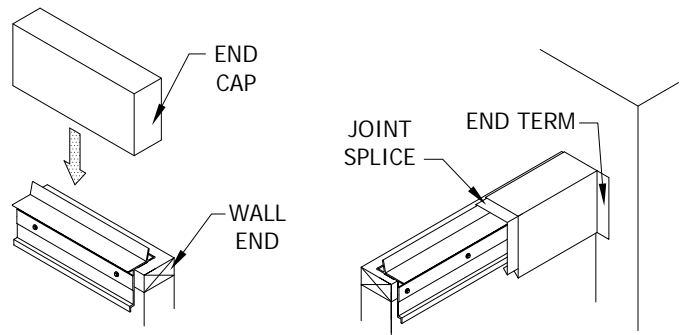

STEP 5: Installing Fascia End Caps and End Terms

Install end caps and end terms by hooking top and pressing top face downward to snap fascia into place (refer to STEP 4).

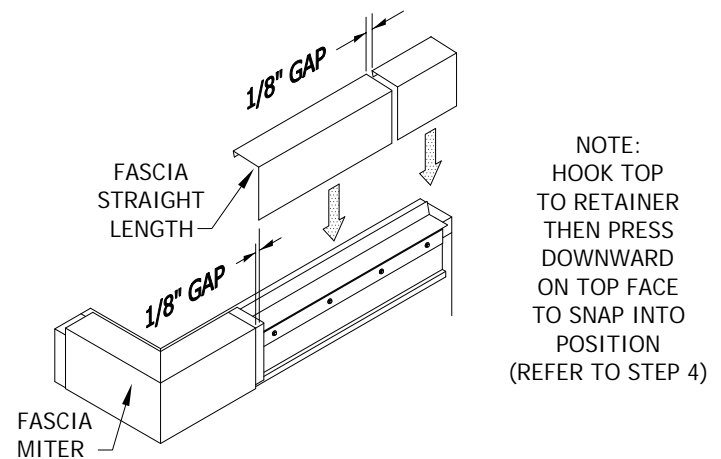

NOTE:
HOOK TOP TO RETAINER THEN PRESS DOWNWARD ON TOP FACE TO SNAP INTO POSITION (REFER TO STEP 4)

STEP 6: Installing Fascia Straight Lengths

Begin installing from the corners and ends working inward to the center. Allow a 1/4" gap between the fascia sections for thermal expansion. Review lengths of all straight pieces prior to cutting to avoid creating relatively short sections of fascia adjacent to full length sections.

Note: There should be a joint splice at every joint.