

## Installation Guide for FlintEdge Fascia GG

ANSI/SPRI ES-1 TESTED

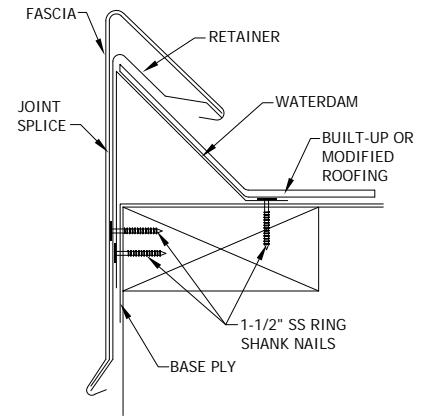

**NOTES:**

#1 - Isolate all metal parts from ACQ treated wood or other galvanically incompatible material with appropriate membrane material.

#2 - Appliance attachments, such as lightning rods, signs, or antennae that penetrate the water seal, induce a galvanic reaction, or otherwise compromise the effectiveness of the roof edge system, shall be eliminated or isolated to prevent problems per section 8.0 of ANSI/SPRI ES-1. Appliances should be isolated from or not attached to the roof edge system. Consult the lightning protection system manufacturer for specific attachment instructions.

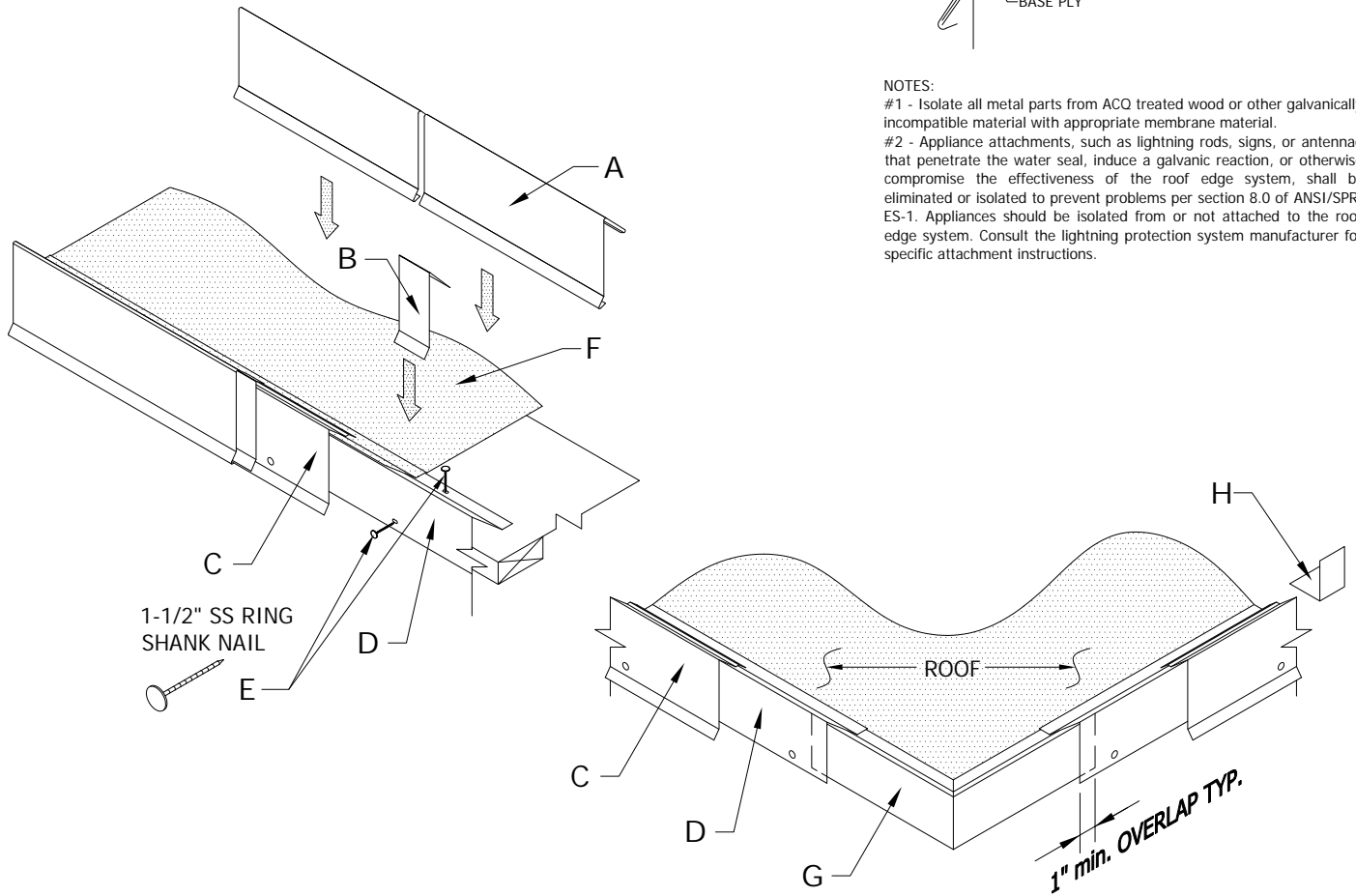

- A. Formed Fascia Cover  
10'-0" Lengths
- B. Concealed Joint Splice  
4" Lengths
- C. Formed Galvanized Retainer  
10'-0" Lengths
- D. Formed Galvanized Waterdam  
10'-0" Lengths

- E. 1-1/2" SS Ring Shank Nail  
at 12" o.c. (6" from ends)  
(Included & Required)
- F. Built-up or Modified Bituman Roofing  
(By Installer)
- G. Corner Support (Outside)  
At All Inside and Outside Corners
- H. Leveling Angle  
Sets Proper Height for Waterdam

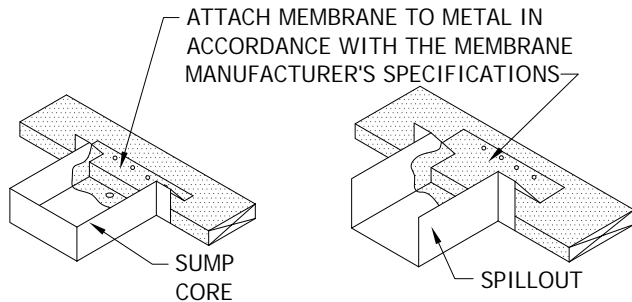

**STEP 1: Consider Sump Core & Spillout Locations**

Locate sump cores where downspouts will be located. Sumps and spillouts are installed prior to the waterdam. The waterdam sections will install over the ears welded onto the sump and spillout core. Refer to "Spillout & Sump Core Install Guides" for more info on installation if necessary.

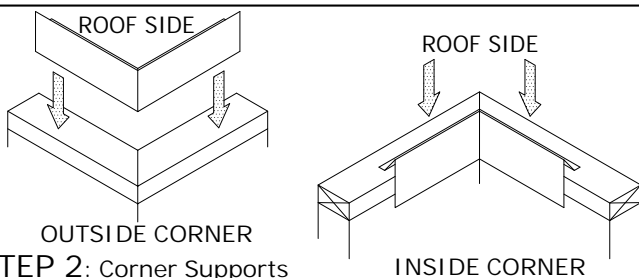

**STEP 2: Corner Supports**

Locate waterdam corner supports at each corner location and fasten in place using 1-1/2" ss ring shank nails provided.

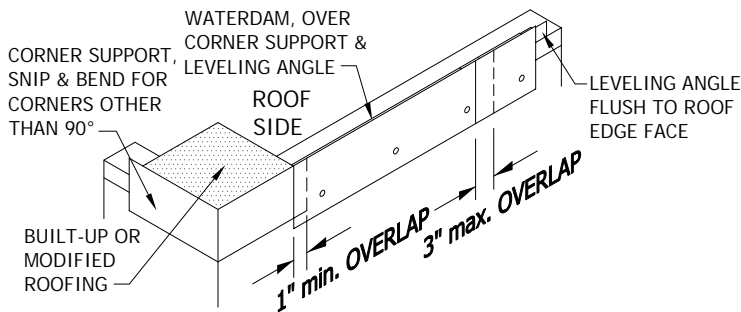

**STEP 3: Waterdam & Built-Up or Modified Bitumen Roofing**

Install waterdam sections by overlapping the waterdam corner support by 1" min. and place a waterdam leveling angle under the opposite end. Fasten in place using 1-1/2" ss ring shank nails provided in each pre-punched holes. Waterdam should be installed from the corners working towards the center. Waterdam sections should overlap each other 3" max. Do not fasten waterdam through laps. Adhere the built-up or modified bituman roofing to the cant side of the waterdam per roofing material manufacturer's instructions.

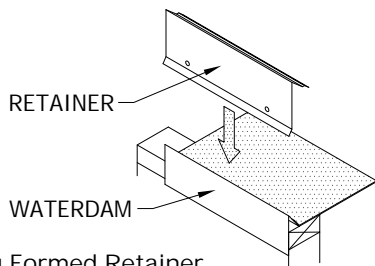

**STEP 4: Installing Formed Retainer**

After the roofing ply has been adhered to the waterdam, install the retainer. Starting at the corner locations and working towards the center, fasten the retainer through each pre-punched holes using 1-1/2" ss ring shank nails provided. Retainer sections to be lapped 3".

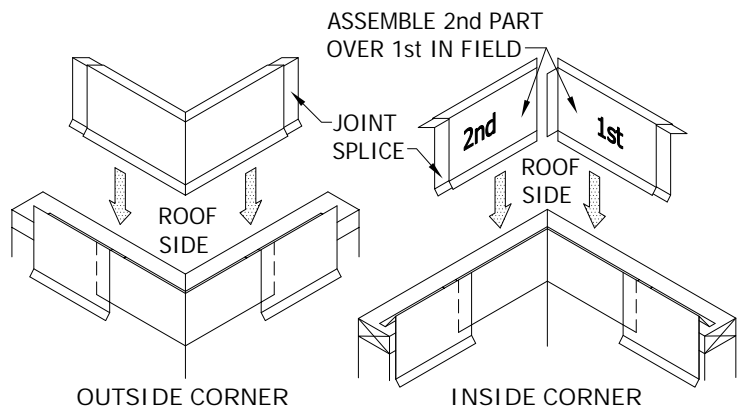

**STEP 5: Installing Fascia Miters**

Locate the miters and concealed joint splices for the appropriate corners. Place a concealed joint splice in each end of the miter sections. Install the miter by pressing downward on the top flange until fascia cover has snapped over the drip of the retainer and the back flange of the retainer. Ensure that both the drip flange and the back flange are fully engaged.

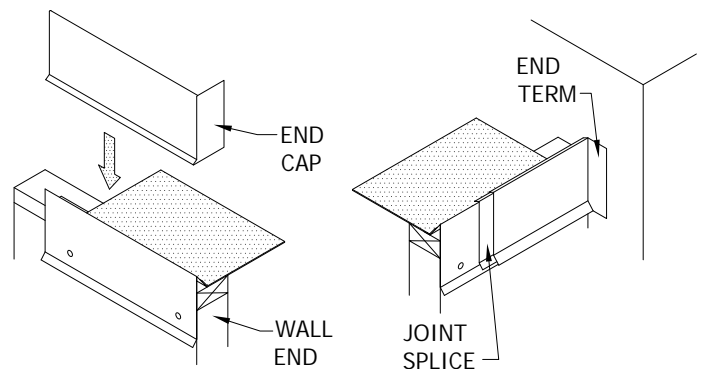

**STEP 6: Installing Fascia End Caps and End Terms**

Install the fascia end caps and end terms by pressing downward on the top flange until fascia cover has snapped over the drip of the retainer and the back flange of the retainer. Ensure that both the drip flange and the back flange are fully engaged.

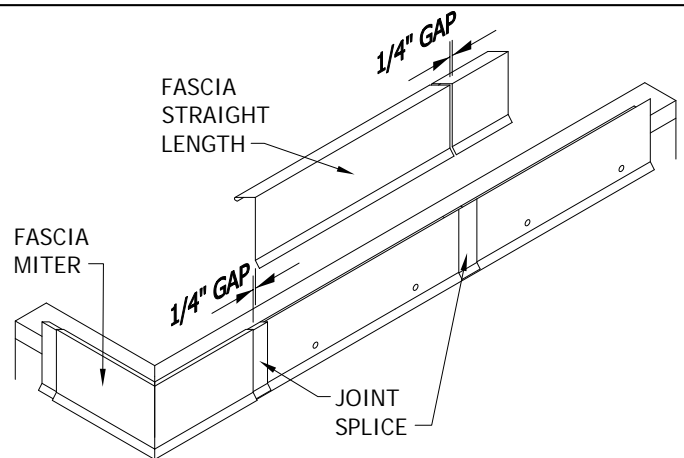

**STEP 7: Installing Fascia Straight Lengths**

Place a concealed joint splice in the opposite end of the installed miter or end cap. Install the fascia by pressing downward on the top flange until fascia cover has snapped over the drip of the retainer and the back flange of the retainer. Ensure that both the drip flange and the back flange are fully engaged. Allow a 1/4" gap between fascia sections for thermal expansion. Review lengths of all straight pieces prior to cutting to avoid creating relatively short sections of fascia adjacent to full length sections. Note: there should be a joint splice at every joint.