

Installation Guide for FlintEdge Concealed Mount Reglet

NOTES:
 #1 - Isolate all metal parts from ACQ treated wood or other galvanically incompatible material with appropriate membrane material.
 #2 - Appliance attachments, such as lightning rods, signs, or antennae that penetrate the water seal, induce a galvanic reaction, or otherwise compromise the effectiveness of the roof edge system, shall be eliminated or isolated to prevent problems per section 8.0 of ANSI/SPRI ES-1. Appliances should be isolated from or not attached to the roof edge system. Consult the lightning protection system manufacturer for specific attachment instructions.

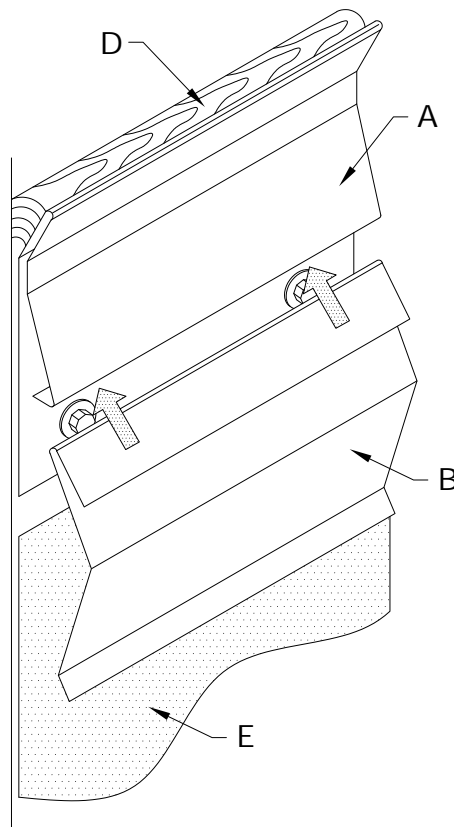
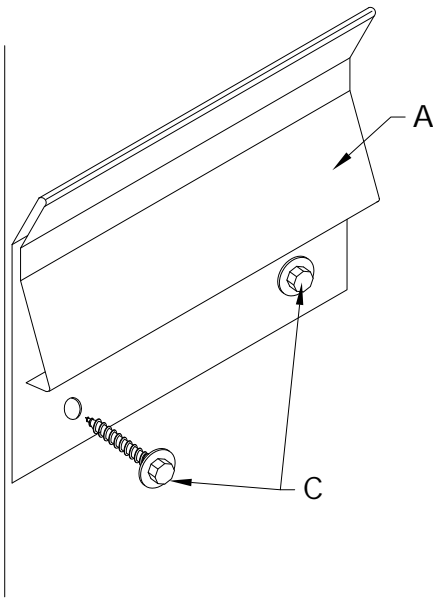
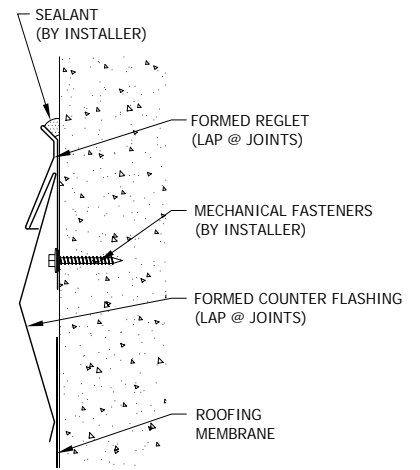

A. Formed Reglet
10'-0" Lengths

B. Formed Counter Flashing
10'-0" Lengths

C. Mechanical Fasteners
at 12" o.c. (6" from ends)
(By Installer)

D. Sealant
Continuous Bead of Sealant, 3/8" Wide
(By Installer)

E. Roofing Membrane
(By Installer)

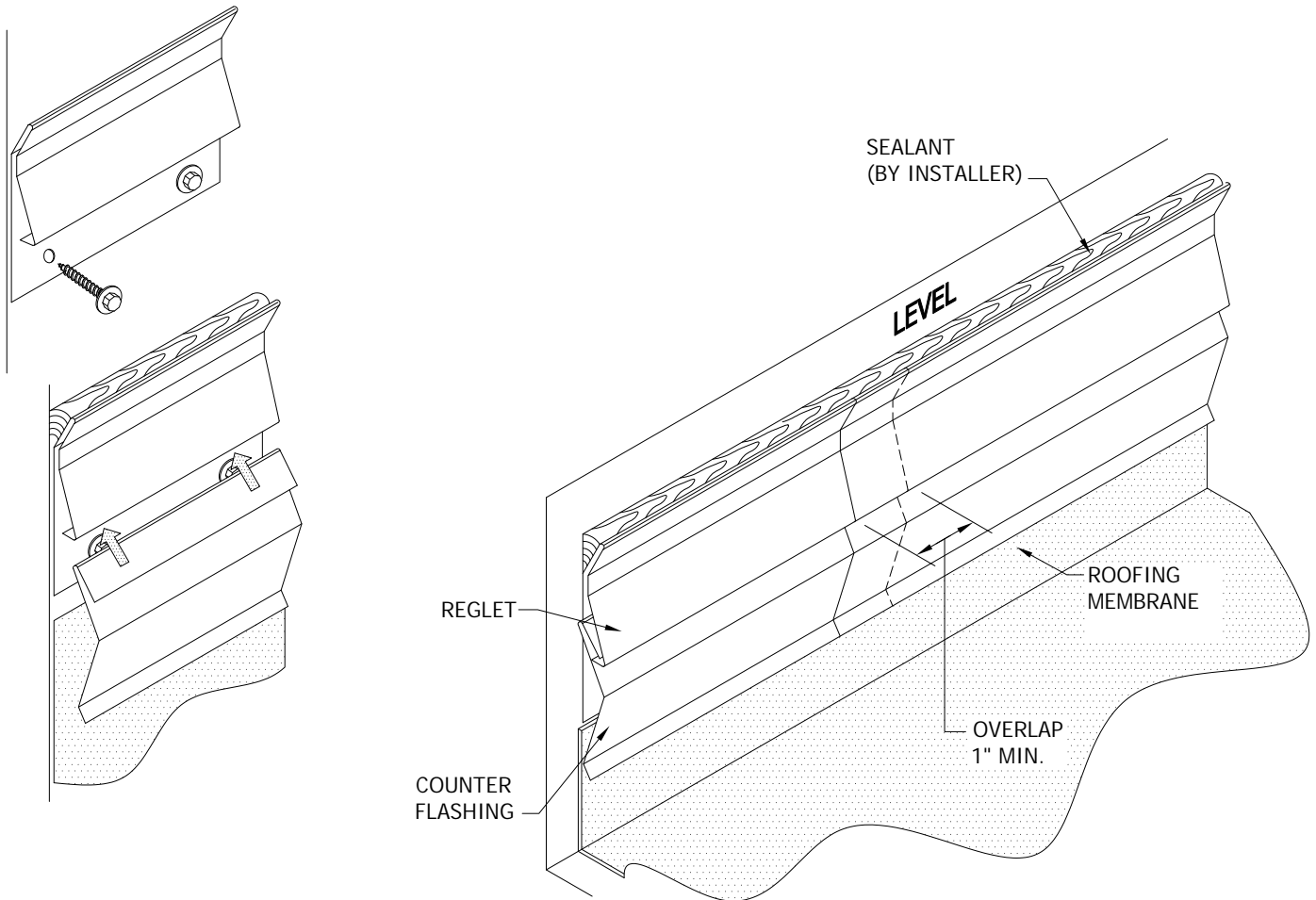

STEP 1: Installation of Reglet

Ensure that roofing membrane is continued up the side wall a min. of 18". Set the reglet over membrane. Attach using mechanical fasteners (by installer). Locate fasteners in each pre-punched holes. Be sure to overlap adjoining piece of reglet a min. of 1" to allow for thermal expansion.

STEP 2: Installation of Counter Flashing

Locate 10'-0" straight lengths of counter flashing below the mounted reglet. Slide the counter flashing up into the reglet receiver until it is fully engaged. Be sure to overlap adjoining piece of counter flashing a min. of 1" to allow for thermal expansion.

STEP 3: Installation of Sealant

Apply a continuous (3/8") wide bead of sealant to the top side of the reglet (see diagram above).

CORNER APPLICATION

Field bevel cut reglet and counter flashing for appropriate corner.