

# Installation Guide for FlintEdge Drain Through GS

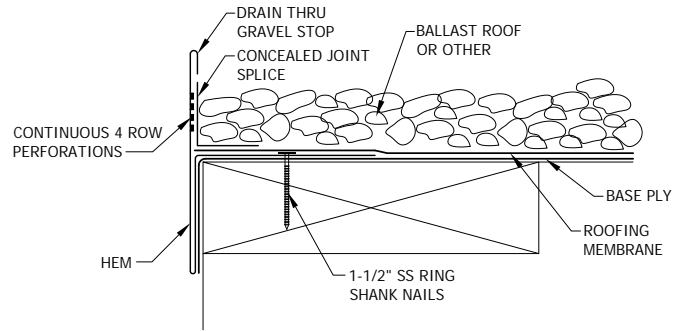

NOTES:  
 #1 - Isolate all metal parts from ACQ treated wood or other galvanically incompatible material with appropriate membrane material.  
 #2 - Appliance attachments, such as lightning rods, signs, or antennae that penetrate the water seal, induce a galvanic reaction, or otherwise compromise the effectiveness of the roof edge system, shall be eliminated or isolated to prevent problems per section 8.0 of ANSI/SPRI ES-1. Appliances should be isolated from or not attached to the roof edge system. Consult the lightning protection system manufacturer for specific attachment instructions.

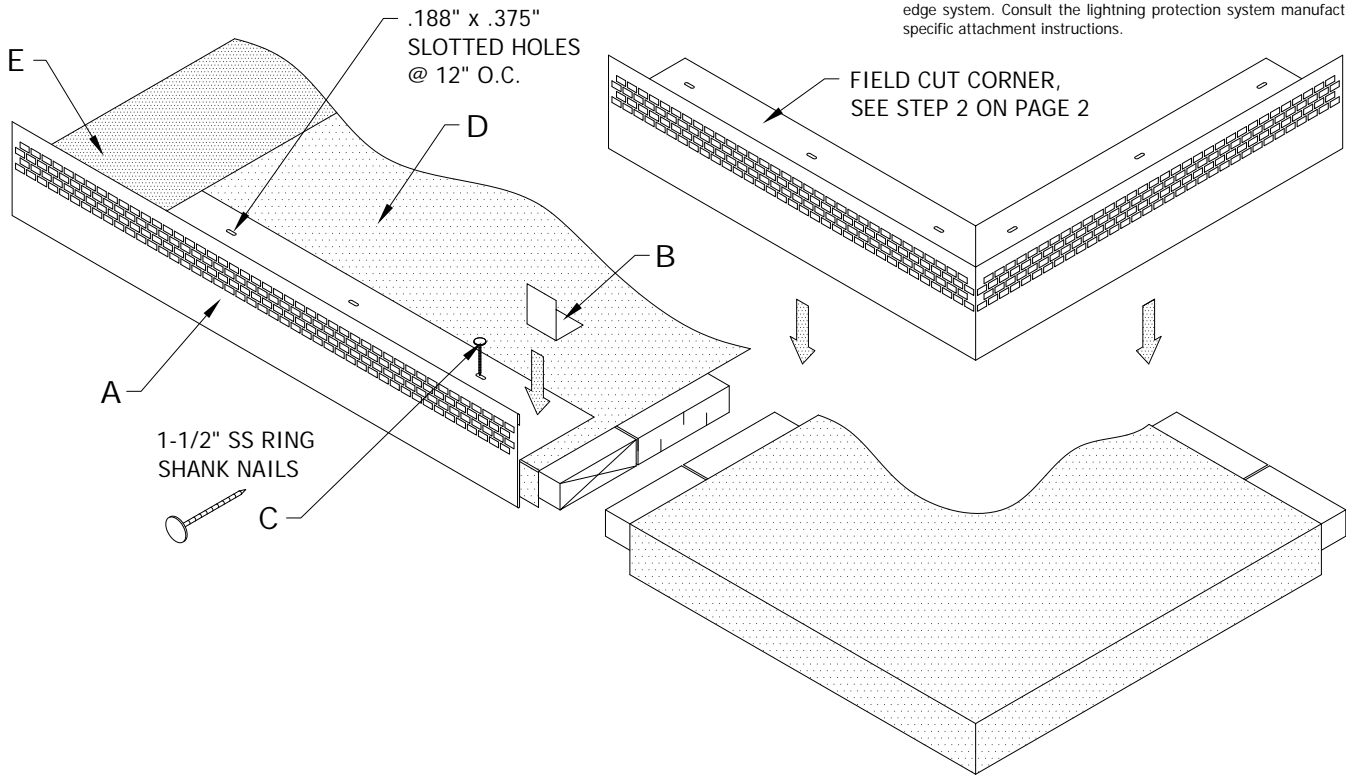

- A. Formed Drain Thru Gravel Stop  
10'-0" Lengths
- B. Concealed Joint Splice  
4" Lengths
- C. 1-1/2" SS Ring Shank Nails  
at 12" o.c. (6" from ends)

- D. Base Ply  
(By Installer)
- E. Roofing Membrane  
(By Installer)

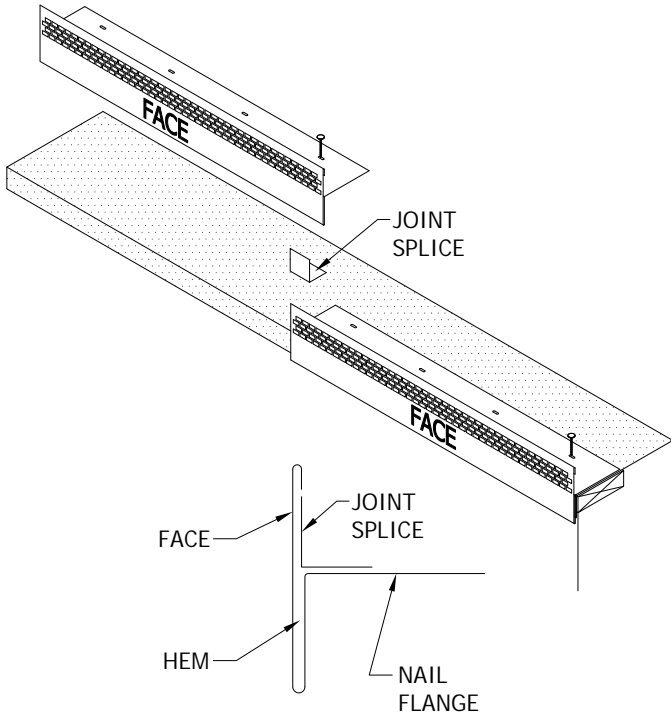

**STEP 1: Installing Drain Thru Straight Lengths**

Place straight lengths at desire location. Nail with fasteners provided by manufacturer in each pre-punched hole. Place the next straight length adjacent to last. Allow an 1/4" gap between the drain thru sections for thermal expansion. Lengths of all straight pieces should be considered prior to cutting to avoid creating relatively short sections of drain thru adjacent to full length sections. Center joint splice at all joint locations and nail in place. Nail joint splice to one end of straight piece as shown below. Nail only one side of joint splice. Caulk & strip in above nail per membrane manufacturers specifications.

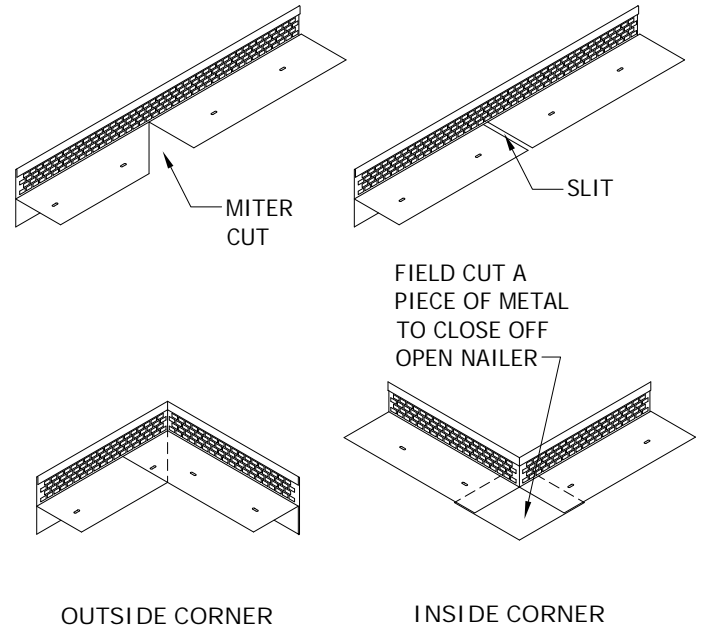
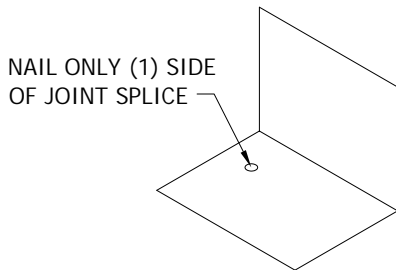

**STEP 2: Installing Drain Thru Miters**

Outside miters: Miter cut a 3' to 4' section at midpoint and fold to required angle.

Inside miters: Slit cut a 3' to 4' section at midpoint and field fold to required angle. Also, cut a section of metal to fit under the flanges.

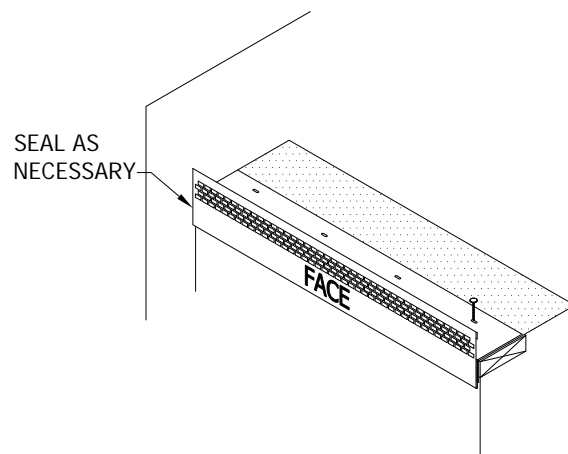

**STEP 3: End Term Conditions**

When terminating the drain thru at an end wall, butt end to wall and seal as necessary.