

Installation Guide for
FlintEdge Gutter - Flat Strap Type
Traditional Gutter

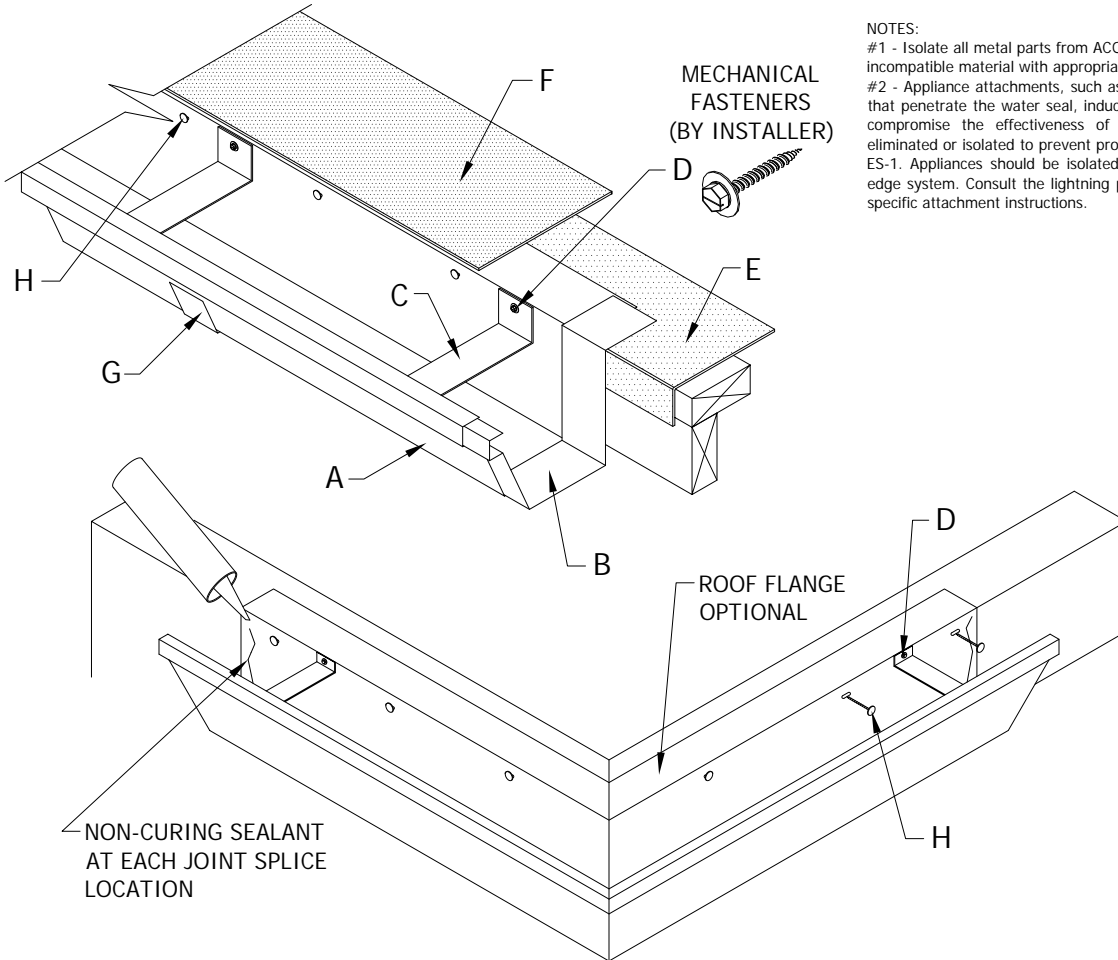
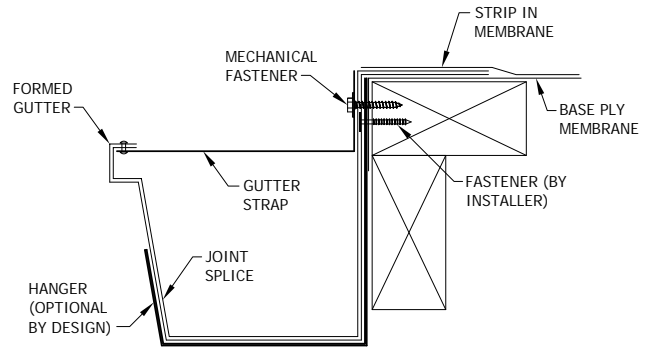

NOTES:

- #1 - Isolate all metal parts from ACQ treated wood or other galvanically incompatible material with appropriate membrane material.
- #2 - Appliance attachments, such as lightning rods, signs, or antennae that penetrate the water seal, induce a galvanic reaction, or otherwise compromise the effectiveness of the roof edge system, shall be eliminated or isolated to prevent problems per section 8.0 of ANSI/SPRI ES-1. Appliances should be isolated from or not attached to the roof edge system. Consult the lightning protection system manufacturer for specific attachment instructions.

- A. Formed Gutter
10'-0" Lengths
- B. Concealed Joint Splice
6" Wide at All Joints
- C. Gutter Strap
(30" On Center Typ.)
- D. Mechanical Fastener
Located at Each Hole & Gutter Strap
(30" On Center Typ., By Installer)
- E. Base Ply Membrane
(By Installer)
- F. Strip In Membrane
(By Installer)
- G. Gutter Hanger
(Optional, by Design)
- H. Gutter Fastener
(By Installer)

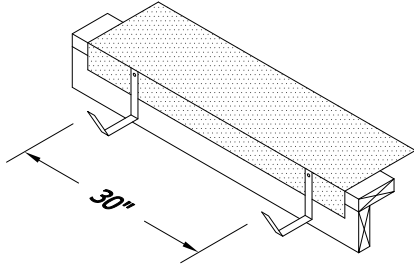

STEP 1: Installing Hanger (Optional, by Design)

Locate appropriate hangers and install @ 30" o.c. using mechanical fasteners in pre-punched holes.

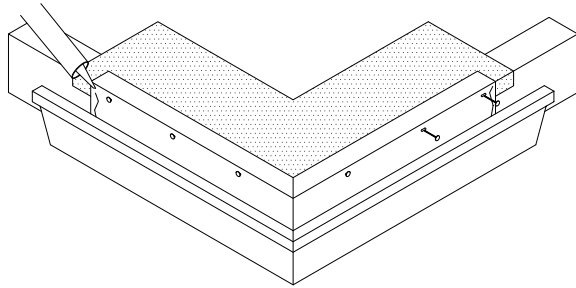

STEP 2: Installing Gutter Miters

Locate the miters and concealed joint splices for the appropriate corners. Install the miter by nailing through pre-punched holes with gutter fasteners (by installer). Apply a heavy bead of non-curing sealant to inside of each miter end. Install a concealed joint splice into each miter end. Pop-Rivet the joint splice @ 2" o.c. Pop-rivets are provided by manufacturer.

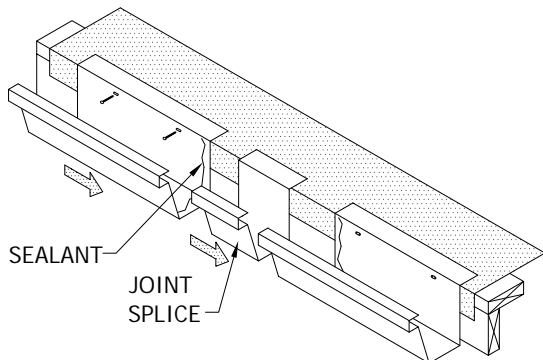

STEP 3: Installing Gutter Straight Lengths

Apply a heavy bead of non-curing sealant to each end of gutter length and insert a concealed joint splice into the end opposite the miter. Install gutter section onto joint splice of miter and nail gutter sections to wood nailers in each pre-punched hole with gutter fasteners. Allow 1/4" gap between gutter sections for thermal expansion. Lengths of all straight pieces should be considered prior to cutting to avoid creating relatively short sections of gutter adjacent to full length sections. Pop-Rivet the joint splice @ 2" o.c. Pop-rivets are provided by manufacturer. Note: there should be a joint splice at every joint.

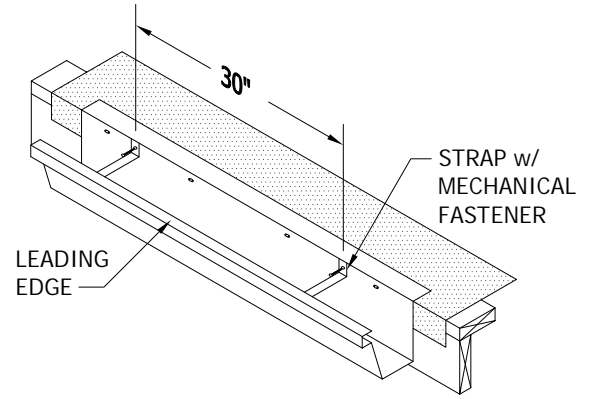

STEP 4: Installing Straps

Slide strap into leading edge of gutter as shown. Install @ 30" o.c. using mechanical fasteners in pre-punched holes.

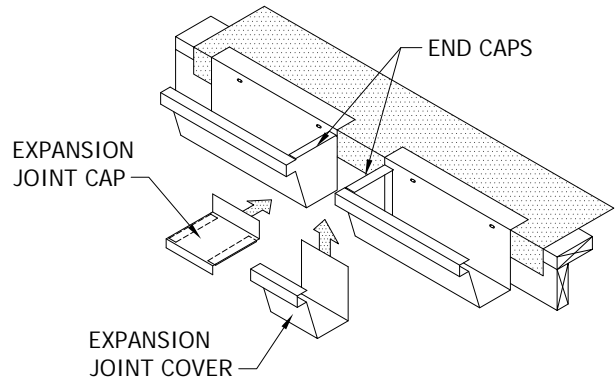

STEP 5: Installing Expansion Joints

Install expansion joint in locations as specified on roof plans or at a maximum of 50'-0". An expansion joint will consist of two pre-fabricated end caps, one expansion joint cap, and one expansion joint cover. Pop-Rivet the expansion joint cover at 2" o.c. Pop-rivets are provided by manufacturer.

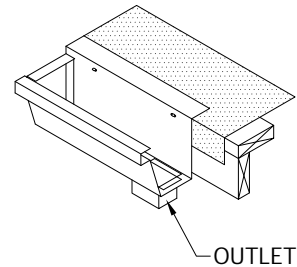

STEP 6: Installing Downspout Outlets

Determine outlet locations and field cut hole in gutter bottom. Insert starter tube outlet (see installation guide for downspout) and fasten with 2 rivets in each flange and seal, with non-curing sealant. Pop-rivets are provided by manufacturer.