

# Installation Guide for FlintEdge Expansion Joint Roof to Roof

**NOTES:**

#1 - Isolate all metal parts from ACQ treated wood or other galvanically incompatible material with appropriate membrane material.  
#2 - Appliance attachments, such as lightning rods, signs, or antennae that penetrate the water seal, induce a galvanic reaction, or otherwise compromise the effectiveness of the roof edge system, shall be eliminated or isolated to prevent problems per section 8.0 of ANSI/SPRI ES-1. Appliances should be isolated from or not attached to the roof edge system. Consult the lightning protection system manufacturer for specific attachment instructions.

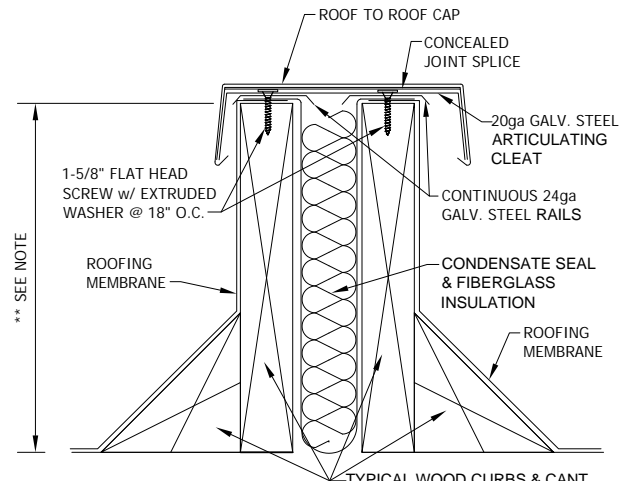

**NOTES:**  
\* TOP SURFACES OF CURBS MUST BE FLAT & LEVEL IN RELATION TO EACH OTHER.  
\*\* INDUSTRY STANDARDS RECOMMEND A MINIMUM 10" CURB HEIGHT ABOVE DECK.

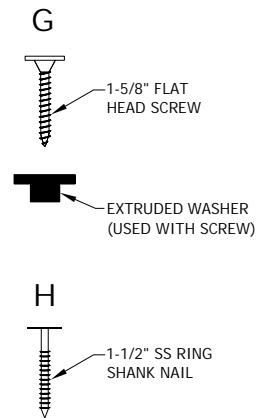
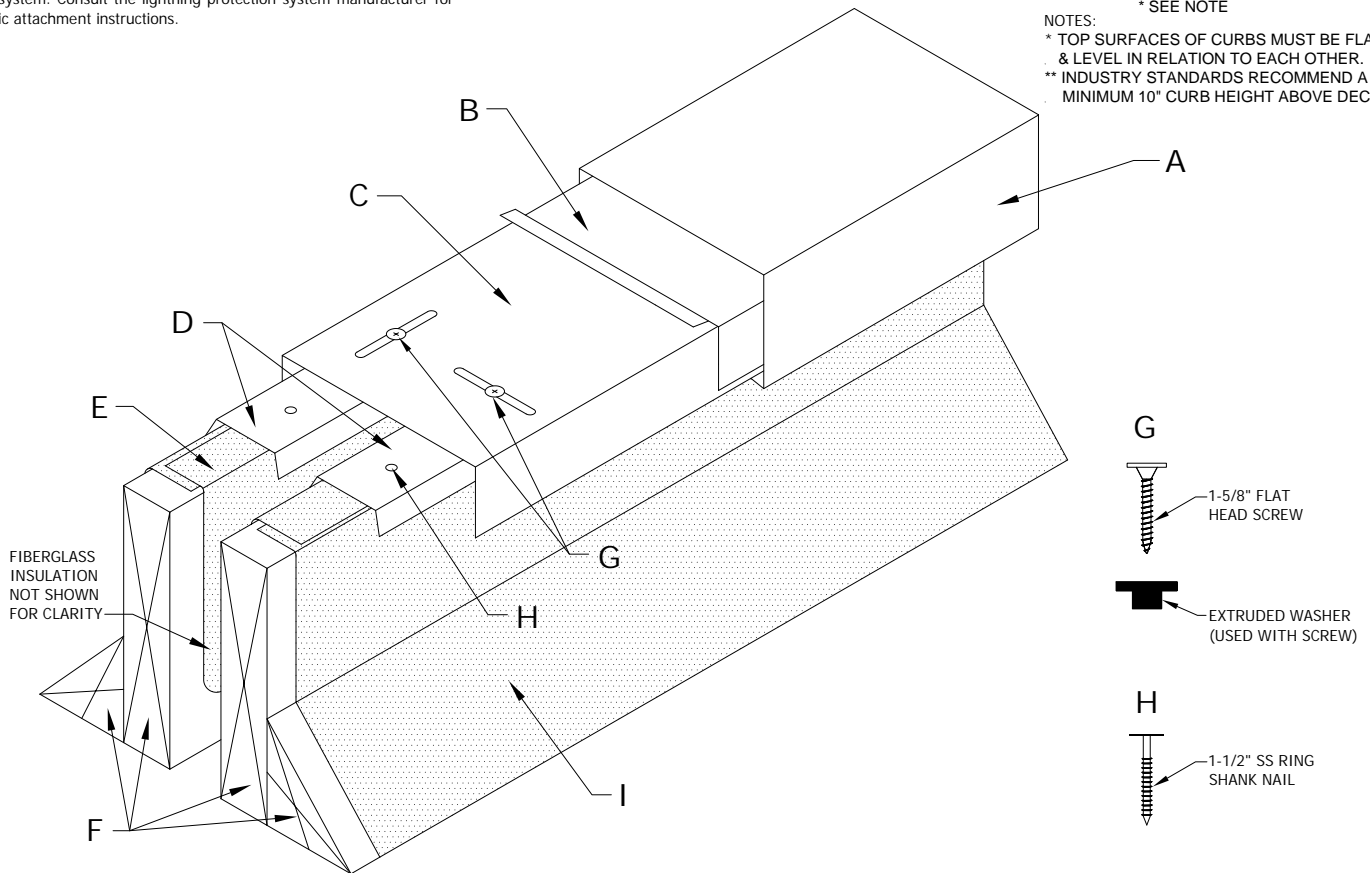

- |   |  |
|---|--|
| <p>A. Formed Roof to Roof Cap<br/>10'-0" Lengths</p> <p>B. Concealed Joint Splice<br/>12" Wide at Each Joint Location</p> <p>C. Galvanized Steel Articulating Cleat<br/>10'-0" Lengths</p> <p>D. Galvanized Steel Rails<br/>10'-0" Lengths</p> <p>E. Condensate Seal &amp; Insulation<br/>(Included &amp; Required)</p> | <p>F. Wood Curb &amp; Cant<br/>(By Contractor)</p> <p>G. 1-5/8" Flat Head Screw w/ Extruded Washer<br/>One (1) Per Pre-Punched Slotted Hole<br/>(Included &amp; Required)</p> <p>H. 1-1/2" SS Ring Shank Nail<br/>One (1) Per Pre-Punched hole<br/>(Included &amp; Required)</p> <p>I. Roofing Membrane<br/>(By Installer)</p> |
|---|--|

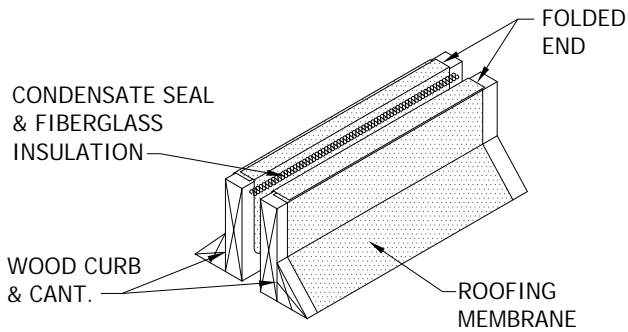

**STEP 1: Installing Condensate Seal & Insulation**

Begin the modular expansion joint by first inserting the condensate seal supplied with the system into the expansion joint gap between the curbs, extending the pocket to the depth of the curbs. Lap and seal all membrane joints. Securely attach the membrane seal to the wood curb with roofing nails sufficient to hold the membrane in place. Trim membrane to be even with the outside edges of the curbs, if necessary. Fold in the ends of the membrane seal and secure to the wood curb. Insert the fiberglass insulation provided with the system into pocket of the membrane.

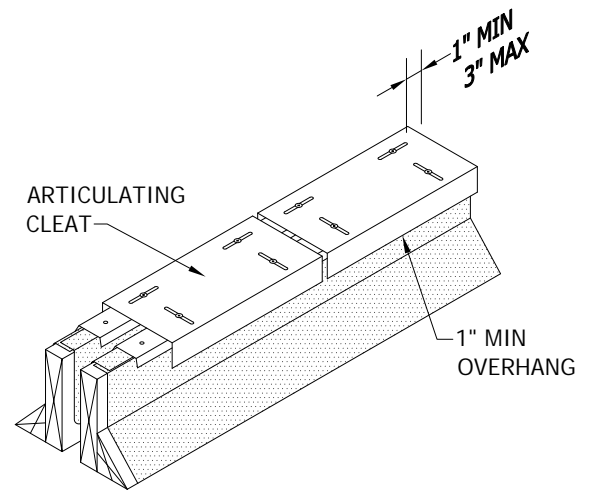

**STEP 3: Installing Galv. Steel Articulating Cleat**

Starting at the ends, loosely lay each 10 foot length of the articulating cleat in place over the expansion joint curbs, be sure to arrange the slots so that the horizontal slots are in line. Cut lengths as needed to completely cover the run of the expansion joint. (NOTE: the cut lengths are to be cut in such a way that the location of last fastener is within 1"min/3" max of the end of run as shown above.) Position the cleat so that the horizontally slotted side is tight up against the rails on the fixed side of the expansion joint. The vertical slots should be pointing in the direction of the free side and the cleat should now extend beyond the free side of the expansion joint. Secure the articulating cleat with the screws and washers provided with the system. The washers are to be located extruded side down in approximately the center of the horizontal slots (approximately in the center of the curb for the vertical slots). The screws are to be driven in place using a #3 square driver - DO NOT OVERDRIVE THE SCREWS INTO THE CLEAT; DOING SO WILL RESTRICT MOVEMENT.

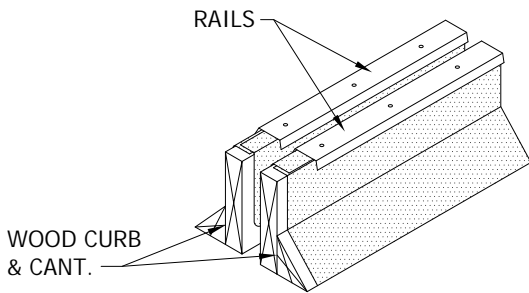

**STEP 2: Installing Galv. Steel Rails**

Secure the galvanized steel rails with fasteners at 24" o.c. to the top of the wood curbs. Use 1-1/2" ss ring shank nails (provided by manufacturer) to hold the rails in place.

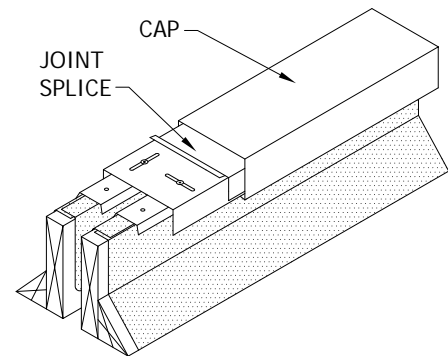

**STEP 4: Installing Cap Straight Lengths**

Begin by installing prefabricated corners, end terminations, or other accessories as required (See STEPS 5 thru 7 for more info.). Carefully place a joint splice at each joint in the exterior cap. Hook the cap on the free side of the expansion joint and rotate the cap, snapping it into place on the fixed side of the expansion joint. This allows support under the side needing pressure to snap into place. Allow a 1/4" gap between cap sections for thermal expansion. Lengths of all straight pieces should be considered prior to cutting to avoid creating relatively short sections of trim adjacent to full length sections.

Note: there should be a joint splice at every joint.

**STEP 5: Installing Miters**

Install condensate seal & insulation by folding membrane and maintaining a continuous seal material at the inside corner (see STEP 1). Attach galv. steel rails by cutting rails at corner locations as required (see STEP 2). Attach pre-manufactured articulating cleat and straight lengths as shown in STEPS 3 & 4.

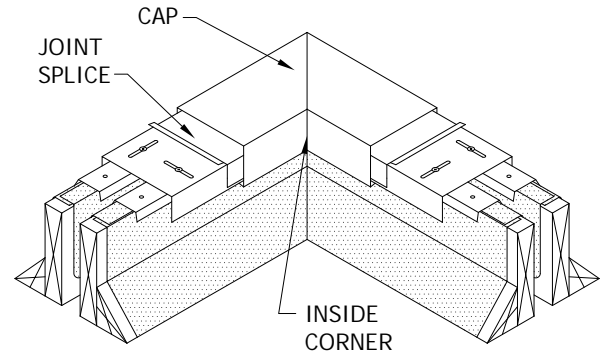

**STEP 6: Installing End Terms**

Install end terms similar to STEPS 1 thru 4. Material ordered for end terms will contain a vertical flange at the wall termination. Alternatively vertical flange can be made by cutting straight piece as required. Seal cap to wall as required by roofing manufacturer.

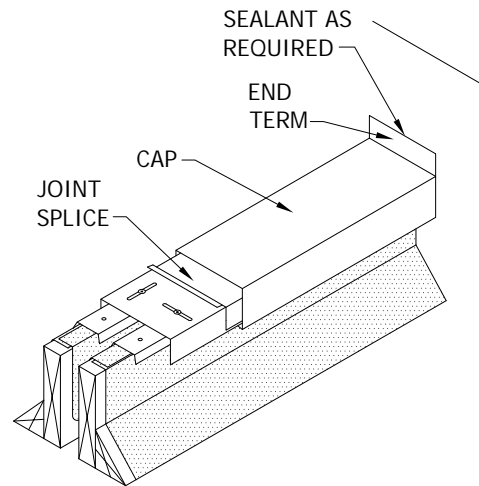

**STEP 7: Installing Eave Conditions**

Install eave conditions similar to STEPS 1 thru 4. Material ordered for eave conditions will contain a end flange to fold over existing fascia as required.

