

Installation Guide for FlintEdge Expansion Joint Roof to Wall

NOTES:

- #1 - Isolate all metal parts from ACQ treated wood or other galvanically incompatible material with appropriate membrane material.
- #2 - Appliance attachments, such as lightning rods, signs, or antennae that penetrate the water seal, induce a galvanic reaction, or otherwise compromise the effectiveness of the roof edge system, shall be eliminated or isolated to prevent problems per section 8.0 of ANSI/SPRI ES-1. Appliances should be isolated from or not attached to the roof edge system. Consult the lightning protection system manufacturer for specific attachment instructions.

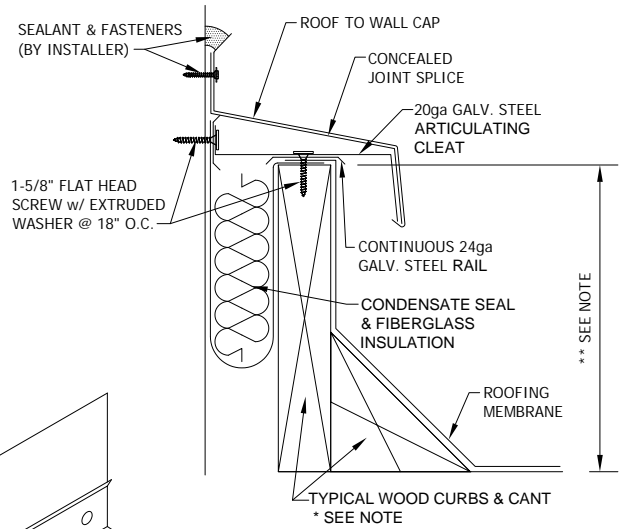

NOTES:

- * TOP SURFACES OF CURBS MUST BE FLAT & LEVEL IN RELATION TO EACH OTHER.
- ** INDUSTRY STANDARDS RECOMMEND A MINIMUM 10" CURB HEIGHT ABOVE DECK.

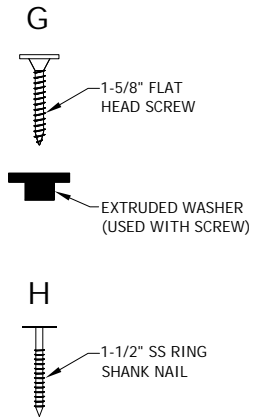
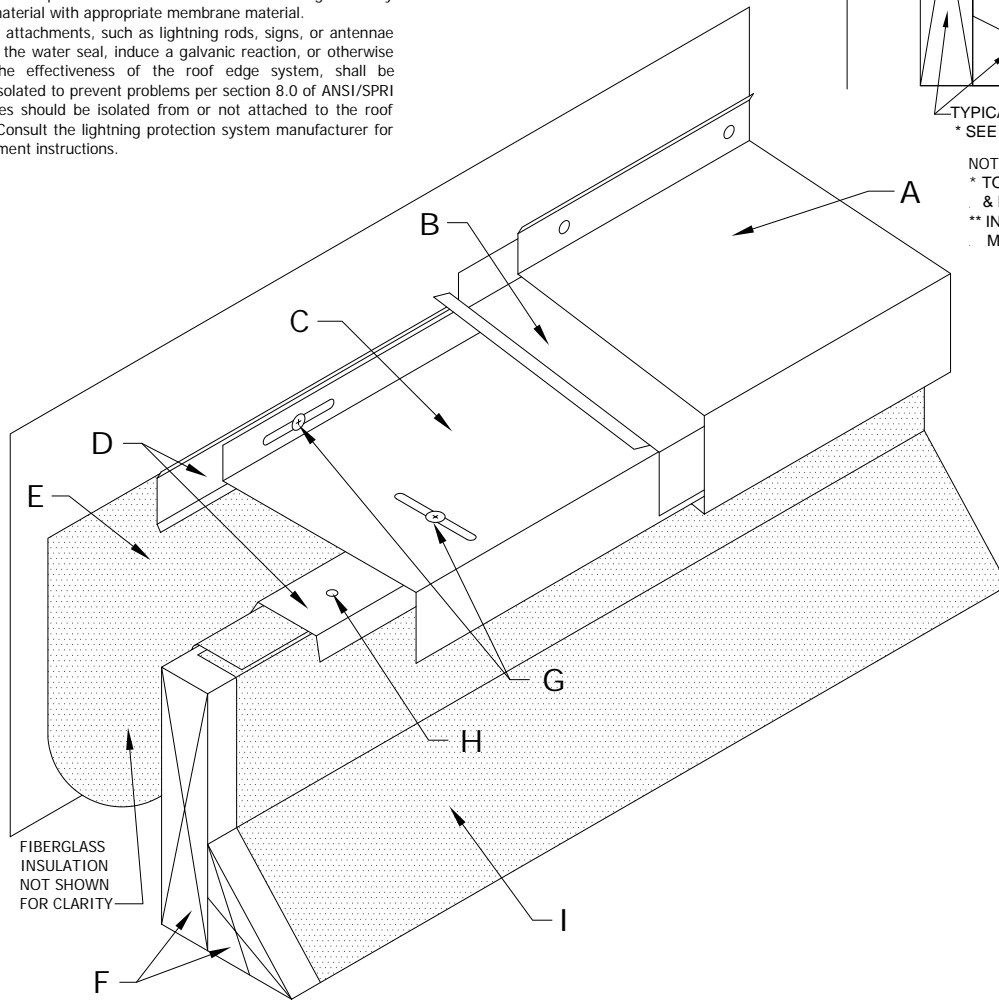

- | | |
|---|--|
| <p>A. Formed Roof to Wall Cap
10'-0" Lengths</p> <p>B. Concealed Joint Splice
12" Wide at Each Joint Location</p> <p>C. Galvanized Steel Articulating Cleat
10'-0" Lengths</p> <p>D. Galvanized Steel Rails
10'-0" Lengths</p> <p>E. Condensate Seal & Insulation
(Included & Required)</p> | <p>F. Wood Curb & Cant
(By Contractor)</p> <p>G. 1-5/8" Flat Head Screw w/ Extruded Washer
One (1) Per Pre-Punched Slotted Hole
(Included & Required)</p> <p>H. 1-1/2" SS Ring Shank Nail
One (1) Per Pre-Punched hole
(Included & Required)</p> <p>I. Roofing Membrane
(By Installer)</p> |
|---|--|

CERTAINTEED ROOFING

750 E. Swedesford Road - Valley Forge, PA 19482 - Phone: (800) 345-1145

www.certainteed.com

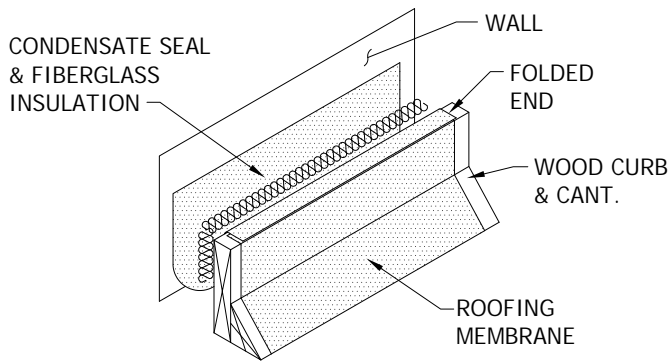

STEP 1: Installing Condensate Seal & Insulation

Begin the modular expansion joint by first inserting the condensate seal supplied with the system into the expansion joint gap between the curb and wall, extending the pocket to the depth of the curb. Lap and seal all membrane joints. Securely attach the membrane seal to the wood curb with roofing nails sufficient to hold the membrane in place and to the wall with nails or tape sufficient to hold the membrane in place. Trim membrane to be even with the outside edge of the curb, if necessary. Fold in the ends of the membrane seal and secure to the wood curb and wall. Insert the fiberglass insulation provided with the system into pocket of the membrane.

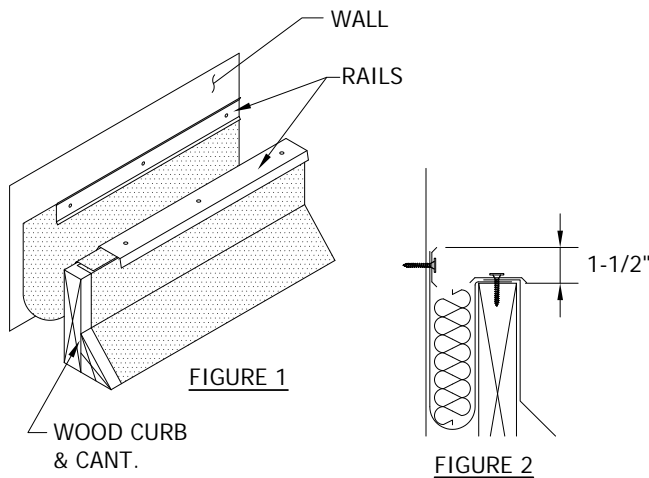

STEP 2: Installing Galv. Steel Rails

Secure one galvanized steel rail to the top of the wood curb with fasteners at 24" o.c. and one galvanized steel rail to the wall with fasteners at 24" o.c. Secure the rail on wall 1-1/2" above wood curb (see Figure 2) and through condensate seal. Secure rail on wood curb with 1-1/2" ss ring shank nails (provided by manufacturer) and rail on wall with appropriate fasteners to hold the steel rails in place.

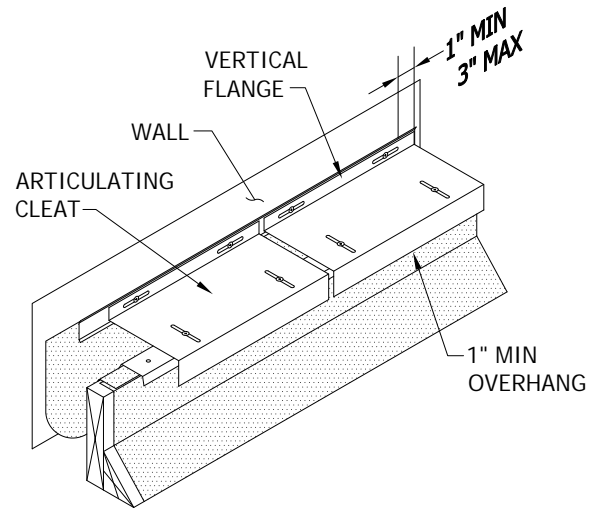

STEP 3: Installing Galv. Steel Articulating Cleat

Starting at the ends, loosely lay each 10 foot length of the articulating cleat in place over the expansion joint curbs, be sure to arrange the slots so that the horizontal slots are in line. Cut lengths as needed to completely cover the run of the expansion joint. (NOTE: the cut lengths are to be cut in such a way that the location of last fastener is within 1" min/3" max of the end of run as shown above.) Position the cleat so that the vertical flange is against the wall on the fixed side of the expansion joint. The cleat should extend beyond the free side of the expansion joint by 1" min. Secure the articulating cleat with the screws and washers provided with the system. The washers are to be located extruded side down in (approximately the center of the horizontal slots (approximately in the center of the curb for the vertical slots). The screws are to be driven in place using a #3 square driver - DO NOT OVERDRIVE THE SCREWS INTO THE CLEAT; DOING SO WILL RESTRICT MOVEMENT.

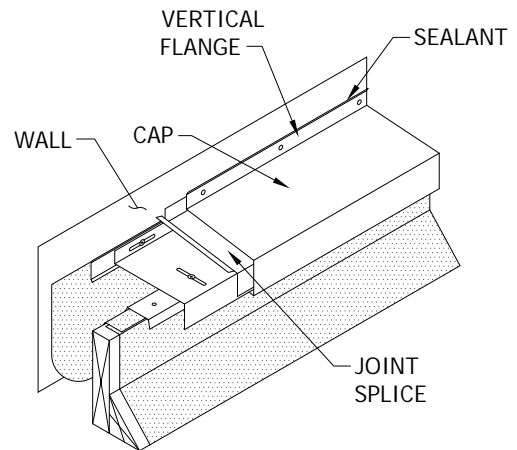

STEP 4: Installing Cap Straight Lengths

Begin by installing prefabricated corners, end terminations, or other accessories as required (See STEPS 5 thru 7 for more info.). Carefully place a joint splice at each joint in the exterior cap. Hook the cap on the free side of the expansion joint and rotate the cap until bottom rests on the steel rail attached on the wall. Fasten the cap to the wall using appropriate fasteners. Apply specified sealant (by installer) in trough at top of vertical flange of cap. Allow a 1/4" gap between cap sections for thermal expansion. Lengths of all straight pieces should be considered prior to cutting to avoid creating relatively short sections of trim adjacent to full length sections.

Note: there should be a joint splice at every joint.

STEP 5: Installing Miters

Install condensate seal & insulation by folding membrane and maintaining a continuous seal material at the inside corner (see STEP 1). Attach galv. steel rails by cutting rails at corner locations as required (see STEP 2). Attach pre-manufactured articulating cleat and straight lengths as shown in STEPS 3 & 4.

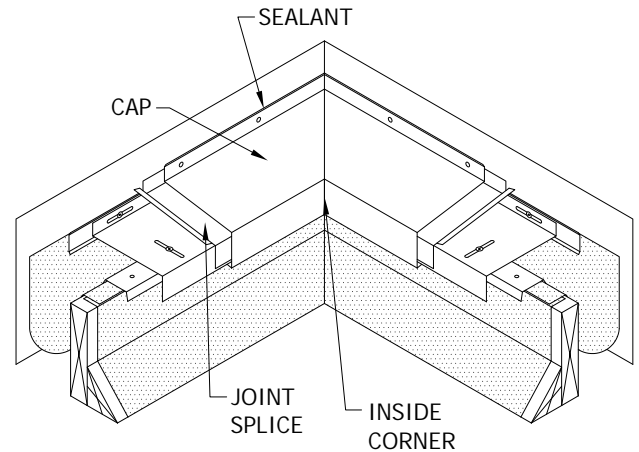

STEP 6: Installing End Terms

Install end terms similar to STEPS 1 thru 4. Material ordered for end terms will contain a vertical flange at the wall termination. Alternatively vertical flange can be made by cutting straight piece as required. Seal cap to wall as required by roofing manufacturer.

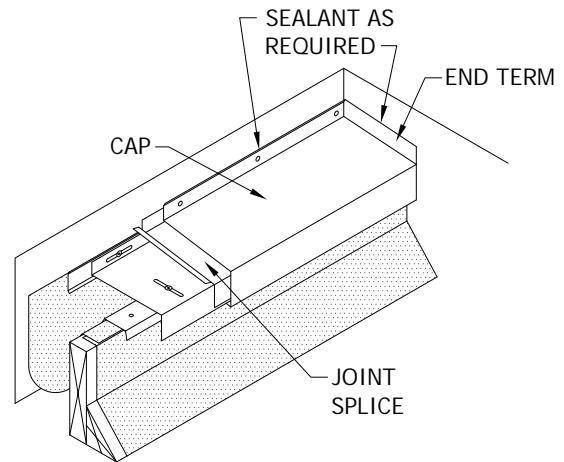

STEP 7: Installing Eave Conditions

Install eave conditions similar to STEPS 1 thru 4. Material ordered for eave conditions will contain a end flange to fold over existing fascia as required. Seal cap to wall as required by roofing manufacturer.

