

Assembly Instructions



STEP-BY-STEP HANDRAIL INSTALLATION

for 1-1/2" vinyl handrail component system

		Run in Inches														
		8	8.5	9	9.5	10	10.5	11	11.5	12	12.5	13	13.5	14	14.5	15
Rise in Inches	8.5	47	45	43	42	40	39	38	36	35	34	33	32	31	30	30
	8	45	43	42	40	39	37	36	35	34	33	32	31	30	29	28
	7.5	43	41	40	38	37	36	34	33	32	31	30	29	28	27	27
	7	41	39	38	36	35	34	32	31	30	29	28	27	27	26	25
	6.5	39	37	36	34	33	32	31	29	28	27	27	26	25	24	23
	6	37	35	34	32	31	30	29	28	27	26	25	24	23	22	22
		Calculated Angle in Degrees														

BEFORE YOU BEGIN

HELPFUL HINTS

Read these instructions thoroughly before beginning the assembly.

- Do not lay vinyl components on abrasive surfaces.
- Do not use excessive force while assembling components.
- If any components are missing or defective, please call us at **800-380-5323**.

CertainTeed

IMPORTANT:

**ALWAYS WEAR SAFETY
GLASSES WHEN CUTTING
OR DRILLING
VINYL PRODUCTS.**

TOOLS REQUIRED

Hacksaw or Chop/Mitre Saw—
with Carbide-Tipped Cutting Blade
Drill
Phillips Head Screwdriver or Bit
3/8" Masonry Drill Bit
(for concrete installation)
3/4" Drill Bit
Tape Measure
Angle Finder
Quick-Clamps
Pencil
Adhesive

Recommended Adhesives

Vinyl Bonding:

- Christy's White Hot Vinyl Cement®

Aluminum Bonding:

- Loctite® Metal/Concrete Epoxy™
- Gorilla™ Epoxy - Impact Tough®
- J-B Weld® - 2 Part Epoxy
- Loctite® Extra Time Epoxy

HANDRAIL APPLICATIONS

Stringer lay-out for Handrail Transition Bends

It is recommended that each of the handrail components be dry fit before final installation to eliminate cutting and gluing errors.

When cutting handrail lineals, always cut the vinyl and aluminum together to the same length using a miter saw with a carbide-tipped blade with at least 60 teeth.

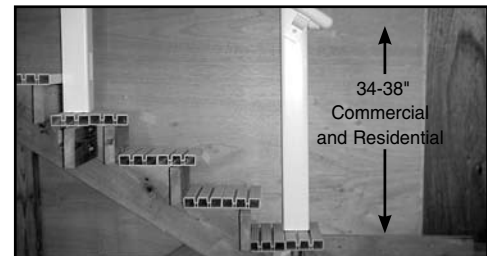

Determine layout of handrail and the requirements at termination points, transitional bends and/or returns to walls or posts. Spacing of brackets should be a maximum of 6' on center.

Determine desired handrail height. Finished handrail height should be 34" to 38" for commercial and residential applications measured from the leading edge of the stair tread or landing to the top of the handrail.

The following instructions will position the handrail at approximately 35" above the landing or stair tread. You may need to make adjustments for your specific application or to meet local building codes.

Refer to the "Suggested Layout" inside for helpful information to get organized.

STANDARD INSTALLATION

ATTACHMENT TO CERTAINTEED VINYL POST SUPPORT SYSTEM

For ramp applications, we recommend using CertainTeed FLAT post support kits and FLAT routed posts.

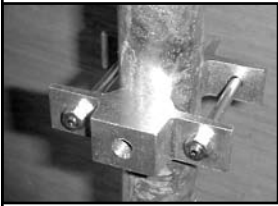

Once post supports are in place, replace one of the standard EZ Set brackets from the

upper location with a special Handrail EZ Set bracket and attach at approximate height position. Install as a minimum the posts and top rail(s) guardrail system.

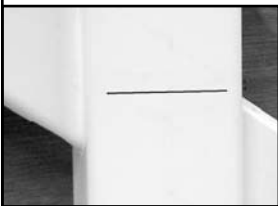

For each post, draw a horizontal pencil line across the post at the point on the downward

side where the (lower) rail meets the post.

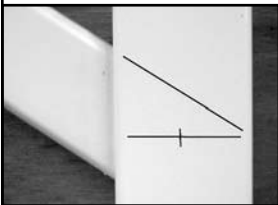

For the bottom end post at the base of the stairs or ramp, you'll need to transfer the

angle of the guardrail diagonally across the post and then connect with a horizontal line.

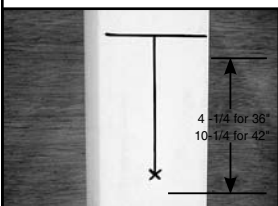

Mark bracket attachment point in center of each post downward from line.

Location of handrail bracket when used with 36" guardrailing is 4-1/4" below line; for 42" guardrailing, it is 10-1/4" below line.

NOTE: Vinyl posts alone do not provide adequate fastener retention. If not using a special EZ Set bracket, you must provide a wood or composite block inside post at bracket locations for proper fastening retention.

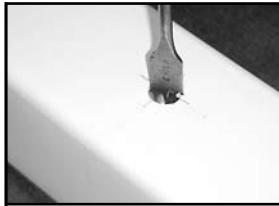

Remove post from assembly. Drill 3/4" hole through side of vinyl post at mark.



Place vinyl post next to steel pipe to transfer this height and position upper EZ Set bracket.

Repeat the above process for all remaining posts.

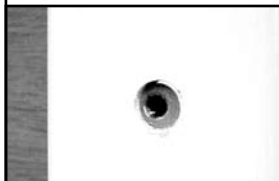

Replace post and guardrail section. (Ensure that 3/4" hole aligns with hole in center of handrail EZ Set bracket for each post).



Attach handrail brackets with 3/8"-16 x 1-1/2" bolts. Do not tighten completely at this time to allow for adjustment.

ATTACHMENT TO CERTAINTEED VINYL SLEEVE-OVER SYSTEM



Using a level and a tape measure, lightly mark the location of the top of the handrail onto the wall or post, at the mounting position and snap a chalk line from top to bottom.

Note: For most applications, the top of the handrail would be 34"-38" above the nose of the stair tread or standing surface.

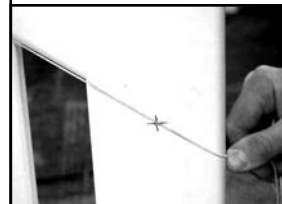

Mark the mounting locations for the brackets on the post at the appropriate height using

a scrap sample of handrail as a guide. Make the top of the handrail consistent at all locations marked above.

Install the mounting bracket to the post with fasteners best suited for your application.

ATTACHING HANDRAIL TO BRACKETS

ATTACHMENT TO CONCRETE WALL



Mark a point 31-1/4" upward vertically from the leading edge of top and bottom stair tread.



Snap a chalk line between marks.

Mark locations for brackets along line

(6' maximum spacing and 1' maximum overhang beyond last bracket).



Using a 3/8" masonry drill bit, drill holes 2-3/4" deep at each location.

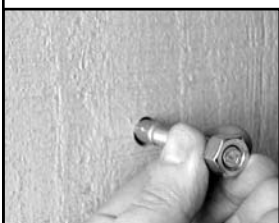

Insert concrete wall anchors and attach handrail brackets (Do not tighten

completely at this time to allow for adjustment).

ATTACHMENT TO WOOD WALL

Ensure that wall is structurally sound.

Follow instructions for concrete wall except bracket attachment point(s) must be on a stud where the string line crosses. Mark bracket attachment locations (6' maximum spacing).

Substitute 3/8" x 2-1/2" long lag screw (not included) in place of the concrete anchor to attach handrail brackets.

ATTACHING HANDRAIL TO BRACKETS

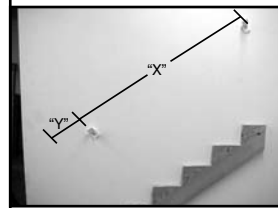

Measure the distance from center of top bracket to center of bottom bracket

along angle (distance "X").

Add any needed additional length to this measurement for handrail extension beyond brackets or posts at both the top and bottom of the section (1 ft. maximum overhang per end; distance "Y").

Note: All splices of handrail must occur within 6" of brackets (no splices beyond the last bracket in a run).



Cut and fit the 1-1/2" vinyl to follow your layout. Starting at the top of the handrail installation

and working towards the bottom, "dry" assemble the various vinyl handrail components according to your diagram. Components can be temporarily clamped in place to the mounting brackets installed to the post or wall, until all final adjustments are made. Mark and trim all vinyl handrail components to proper length and test for tight fit.

When cutting handrail lineals, always cut the vinyl and aluminum together to the same length using a miter saw with a carbide-tipped blade with at least 60 teeth.

ATTACHING HANDRAIL TO BRACKETS (CONTINUED)

STRAIGHT JOINER- F74070

NOTE: For maximum strength, all handrail joints should be supported by a handrail bracket at the joint, or at the nearest possible location.

1. Cut handrail lineals to length.
2. Permanently attach the first handrail lineal.
3. Apply aluminum adhesive and slide the internal joiner halfway into the vinyl lineal.

TIP: If preferred, the handrail joint ring can be installed to conceal the joint using a dab of vinyl adhesive before second lineal is installed. Refer to the first page of this guide for more information.

4. Apply adhesive to the second handrail lineal. Slide handrail lineal onto joiner. Mount in place.

ADJUSTABLE JOINER- F74062



NOTE: All adjustable joiners should be supported by a handrail bracket as closely as possible to each side of the joint.

1. Measure the angle of the joint and cut lineals accordingly. Dry fit both handrail lineals, making sure that the miter cuts match properly.

TIP: While lineals are in place, reference marks can be made on the lineals and mounting hardware, to ensure proper alignment during final installation.

2. Position the adjustable joiner on the outside of the handrail and tighten the bolt at the appropriate angle.
3. Dry fit the assembly and adjust if necessary.

TIP: Use the joiner bolt as a reference to keep the miter cuts in proper alignment, aligning the center of the bolt with the miter cut.



4. Apply aluminum adhesive and assemble the joint.



5. Permanently attach the handrail lineals to the mounting support.

6. Insert the adjustable joiner into the attached handrail lineal. Slide the second handrail onto the adjustable joiner and permanently attach.

NOTE: Joint should be clamped in place until adhesive has had time to cure.



Once all components are glued and temporarily clamped to brackets secure your finished

handrail assembly to the brackets by using two #10-16 x 1" screws provided.



Pre-drill and insert screws from below. Repeat at all bracket locations. Check handrail

for overall strength, adding additional aluminum brackets, as needed, to achieve desired strength.

SUGGESTED LAYOUT

VINYL HANDRAIL COMPONENT SYSTEM

- Complies with ADA (Americans with Disabilities Act) requirements for grippable handrails
- 1-1/2" diameter gripping area
- Continuous handrail runs
- Safe for stair and ramp applications
- Aluminum reinforced construction reduces bowing and provides enduring strength
- Functional finishing touches: post and wall returns, end caps and loops
- Unique adjustable internal joiner accommodates any transition – 0° to 90° bends
- Installs easily on site with no preformed fittings
- Ideal for use with EverNew® railing systems
- Virtually maintenance free
- Lifetime limited warranty
- EZ Set bracket kit available for attachment to routed system

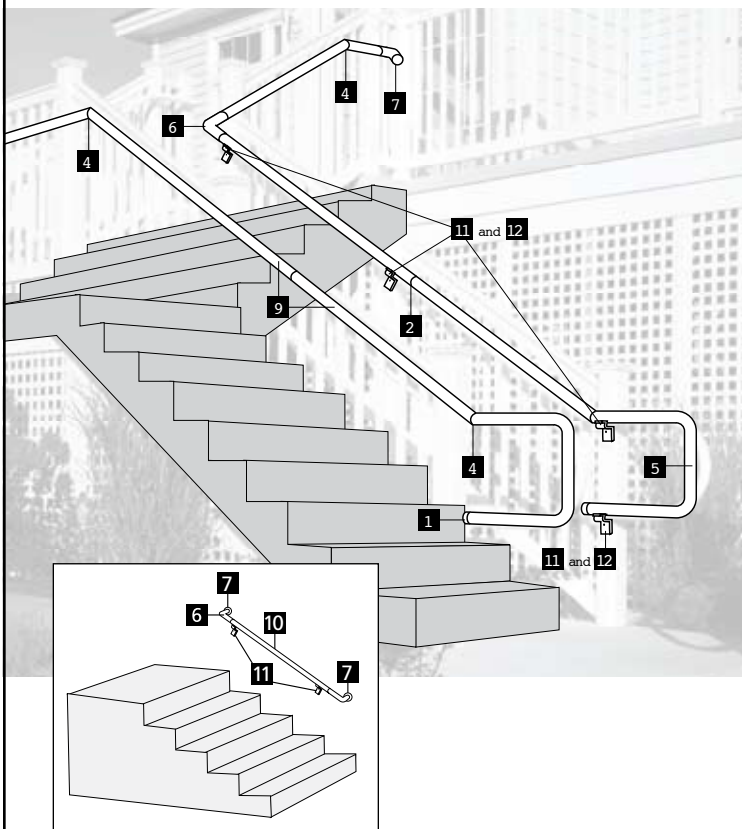
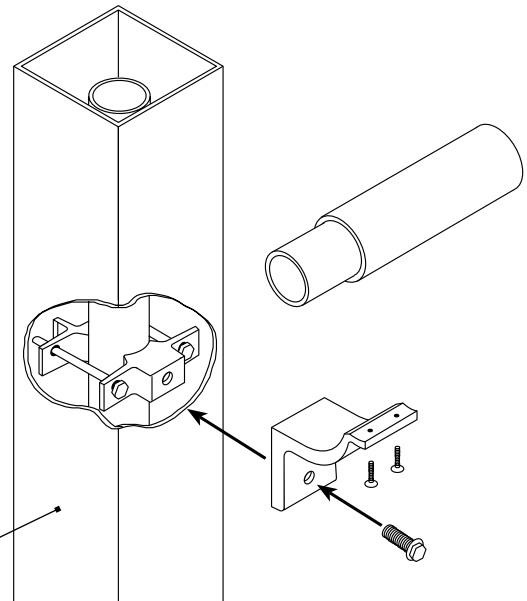

1. 1-1/2" diameter vinyl end cap
2. Straight aluminum joiner
3. Straight wall return (includes vinyl trim)
4. Adjustable aluminum internal joiner
5. 1-1/2" OD ADA 180° return loop
6. 1-1/2" OD - 90° corner - includes two 3" aluminum joiners
7. 1-1/2" OD - 90° wall return - includes 3" aluminum joiner
8. 1-1/2" OD x 80" vinyl handrail with aluminum insert
9. 1-1/2" OD x 104" vinyl handrail with aluminum insert
10. 1-1/2" OD x 120" vinyl handrail with aluminum insert
11. Handrail bracket assembly
12. Handrail EZ Post attach kit

Note: handrail depicted is not free standing and must be anchored to walls or guardrail using handrail bracket assembly (E74028/E74029). Space a maximum of 6' on center and as close as possible to both sides of any joint.

CARE AND MAINTENANCE

CARE & MAINTENANCE

Exterior vinyl building materials require very little maintenance. Nevertheless, common sense dictates that builders and suppliers of vinyl products store, handle, and install vinyl materials in a manner that avoids damage to the product or structure.

CertainTeed deck and railing is not difficult to work with, but there are a few precautions that you should know about before you begin to unload and install the product. Always place planks, posts, rails, and accessories on a non-abrasive surface, such as a drop cloth or cardboard, to avoid scratches. Protect all components during transport. Finally, when assembling the deck and railing, avoid over-tightening the screws.

CLEANING

CertainTeed vinyl deck and railing resists most common household stains, including oil and grease. But, like any other product, it will get dirty when it is exposed to the atmosphere. Chalk may also accumulate on the surface. This is a normal condition for all pigmented materials that are constantly exposed to sunlight and the elements. Soil, grime, and chalk can be removed with a garden hose and a bucket of soapy water.

In some areas, mildew may be a problem. Mildew appears as black spots on surface dirt and is usually first detected in areas not subjected to rainfall, such as eaves and porch enclosures. You can remove mildew from vinyl deck and railing with the solution below.

CAUTION: CLEANING SOLUTION MIXED AT GREATER CONCENTRATIONS MAY HARM THE VINYL.

Mix together:

- 1/3 cup detergent (Tide, for example)
- 2/3 cup trisodium phosphate (Soilex, for example)
- 1 qt. 5% sodium hypochlorite (Clorox, for example)
- 3 qt. water

If the above solution does not readily remove the mildew spots, purchase a mildew cleaner from your local hardware store. Before you use any commercial cleaner, test it on an inconspicuous area.

The chemical agents mentioned above may be hazardous to the user or to the environment. Be sure to follow all precautions and warnings on the product label, particularly those that may be necessary to prevent personal injury. Please DISCARD these chemical agents in the manner prescribed by the manufacturer. If you are unsure how to use or dispose of these chemical agents, contact the manufacturer.

IMPORTANT FIRE INFORMATION

Rigid vinyl deck and railing are made from organic materials that will not burn on their own but melt or burn when exposed to a significant source of flame or heat. Consequently, owners and installers should take a few simple steps to protect vinyl building materials from fire. Building owners, occupants, and outside maintenance personnel should always take normal precautions to keep sources of fire, such as barbecues, and combustible materials like dry leaves, mulch and trash, away from vinyl deck and railing.

Christy's White Hot Vinyl Cement is a registered trademark of T. Christy Enterprises, Inc.

Loctite is a registered trademark of Henkel Corporation

Epoxy Impact Tough is registered a trademark of The Gorilla Glue Company

ASK ABOUT OUR OTHER CERTAINTTEED PRODUCTS AND SYSTEMS:

EXTERIOR: ROOFING • SIDING • WINDOWS • FENCE • RAILING • TRIM • DECKING • FOUNDATIONS • PIPE
INTERIOR: INSULATION • GYPSUM • CEILINGS

CertainTeed Corporation
P.O. Box 860
Valley Forge, PA 19482

Professional: 800-233-8990
Consumer: 800-782-8777
www.certainteed.com

CertainTeed 